

# NATIONAL RADIO NEWS

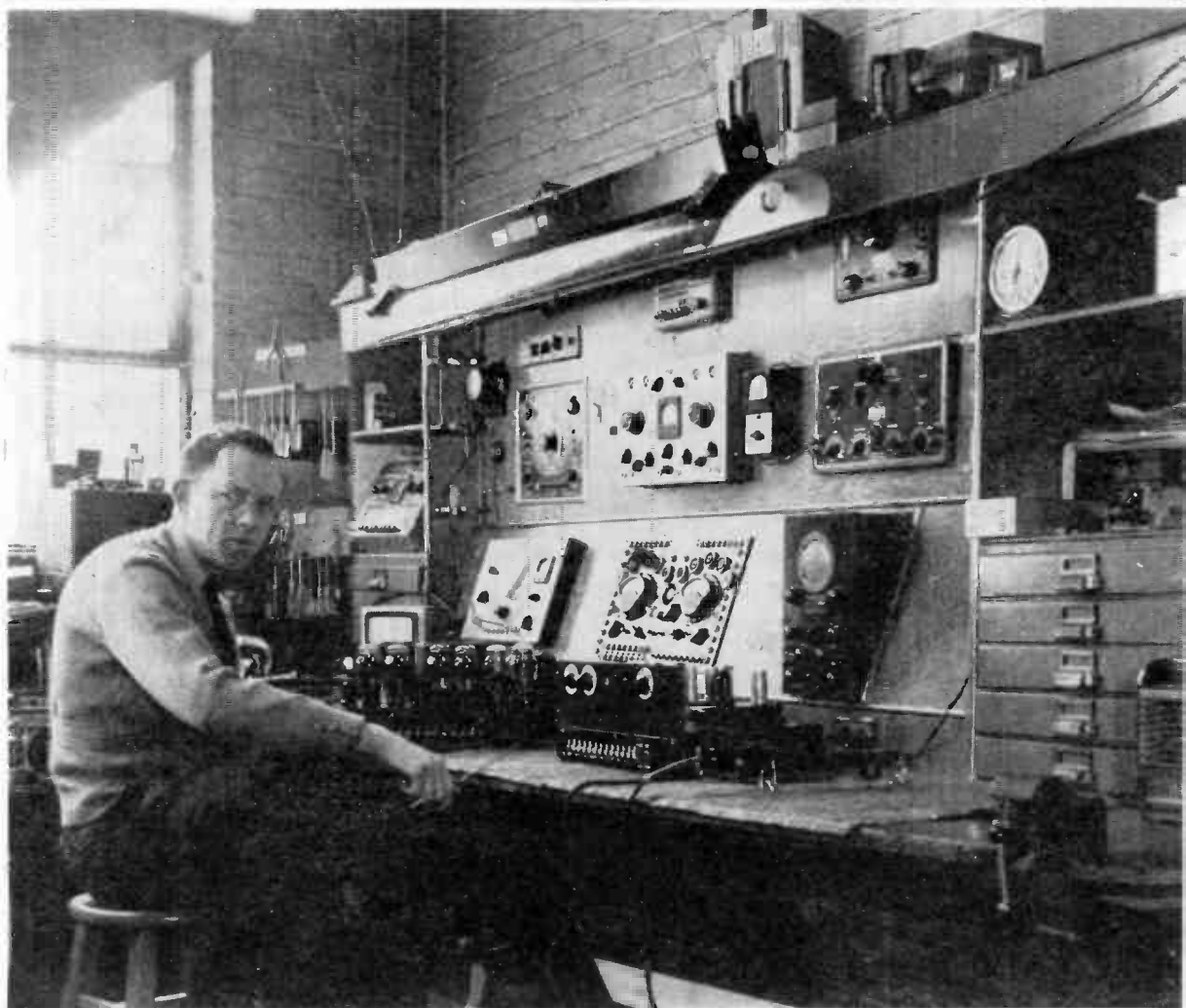

## IN THIS ISSUE

Hints For Wartime Servicing Problems  
Ohmmeters And How To Use Them  
Alumni Association News

OCT.-NOV.  
1943

VOL. 10  
NO. 11



---

---

## ON DOING THE IMPOSSIBLE

You have undoubtedly heard the now famous expression of General H. H. Arnold of the United States Army: "The difficult we do at once; the impossible takes a little longer." This may seem just a piece of healthy boastfulness, but a man's general approach to that word "impossible" is a matter of vital importance, affecting his whole success or failure.

To a vast number of struggling, confined, unsuccessful human beings, the term "impossible" is like a closed gate, barring them from continuing down the path that leads to a more satisfying life. When these people encounter any objective to which the word is applied, that objective is lost to them. They turn away from the "impossible" without the slightest attempt to get *behind* the known facts, to find out just *why* the particular accomplishment which might have been theirs has this awful word attached to it. And in this way they lose not only financial success, but every chance to get the permanent satisfaction that comes only from doing something creative, new, and outstanding.

The important thing to remember is that "impossible" is applied in the majority of cases simply because *nobody has done that particular thing before*. The history of science is full of thrilling examples of men doing the "impossible"—the steamboat, the airplane, the radio, and many, many more. Naturally those were brilliant men, who were responsible for doing these things, but more important to their success is the fact that they refused to accept the blind judgment of others which called their objectives "impossible." They threw off the old thinking on the subject and approached it with a determination to find out *really* why it had not been done and *how* it might be done. They kept banging away at it until they found a way to do it.

This is the approach to the "impossible" that works not only in science and invention, but in bringing to all of us the satisfactions we seek in life. If you develop the psychology that finds the "impossible" not a closed gate but a challenge to you to achieve and move forward into new fields, then you are a man marked for success and happiness.

E. R. HAAS, *Executive Vice President.*

# Hints For Wartime Servicing Problems

By LEO M. CONNER

W3GUP

Member, N. R. I. Instruction Staff



**A**N increasingly large number of requests are coming to the Technical Department for assistance in service problems brought about by the war emergency. A few hints may be helpful.

It should be borne in mind that the suggestions to be given here are emergency measures. Whenever possible the correct replacement part should be used. However, the requests for help being received indicates that the problem of getting correct replacement parts is often a serious one. The following substitute methods will make it possible to restore operation of the set when correct replacement parts are not available.

Quite a few of these requests for help involve tubes for which replacements cannot be obtained.

The 35Z5 tube is one that is frequently asked about. This tube, as most servicemen know, has a tapped filament. The whole filament is connected between pin No. 2 and pin No. 7 with the tapped portion being connected between pin No. 2 and pin No. 3 as shown in Fig. 1A.

The section between pins Nos. 2 and 3 frequently opens up. This section is known as the pilot lamp section, because the pilot lamp is usually connected across it. If a continuity check with an ohmmeter between pins Nos. 2 and 3 shows an open circuit, then the receiver can be placed in operating condition without a new tube. All that is necessary is to place a direct wire connection between pin No. 2 and pin No. 3. If this is done, continuity will be restored in the filament string and the set will operate, but the pilot light will not light, because, the pilot bulb is

short-circuited by the wire connection. This connection should be made after the tube has been inserted in the socket and to the ends of the pins. In this way, it will be impossible to remove the tube to install a new one unless the shorting wire is removed. A note inserted in the chassis on a piece of paper will serve as a reminder of this

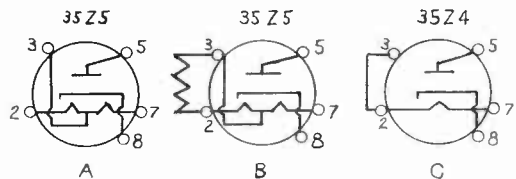

Fig. 1

fact. A diagram should be pasted in a conspicuous spot on the chassis or inside the cabinet as a record of circuit changes made. This should be done in all cases.

If it is desired to restore operation of the pilot light, then the direct connection between pins Nos. 2 and 3 is omitted and a 25-ohm, 2-watt resistor is connected between pins Nos. 2 and 3 as shown in Fig. 1B. This will restore the entire set to normal operation. However, if the filament section between pin No. 3 and pin No. 7 is open a new tube must be used because this section is the heater part of the filament.

It is very necessary when using either of the above methods that the filter condensers be checked with an ohmmeter for excess leakage. It is entirely possible that they caused the orig-

inal trouble. If the condensers show excess leakage they should be replaced before any attempt is made to restore the rest of the set to operating condition.

In certain sections of the country, there is a scarcity of 35Z5 tubes while 35Z4 tubes are plentiful. A 35Z4 tube can be substituted for a 35Z5 and normal receiver operation, save for the pilot lamp, restored by shorting pins Nos. 2 and 3 as shown in Fig.1C. The pilot light is shunted by the direct connection and cannot be operated when this method is used.

In some high voltage filament tubes a burned out filament can be repaired by "flash welding." This process is not "sure fire" but works often enough to make an attempt worth while, particularly if the open is intermittent in nature. Do not use this when the tap on a 35Z5 is open.

If the broken filament ends are not too widely separated a high voltage *applied for an instant* will cause a spark to jump across the open space in the filament and, in the process develop enough heat to weld the break. In some cases, the weld will be permanent and in others, operation will be restored for a few hours while in some cases no weld will take place.

There are instances where a 50L6 has been restored to operation by a momentary application of 110 volts a.c. to the filament. The voltage must not be applied for more than an instant, otherwise the tube will be burned out even if the filament is welded.

The high voltage may be applied with a regular tube tester by setting the filament selector switch on the 117-volt position.

In some sections of the country, there exists a great scarcity of 12-volt tubes. Quite often, a 6-volt tube of the proper characteristics can be located, or no 50L6 can be found but a supply of 35L6 tubes is available. Figure 2A shows a typical 5-tube line-up. Suppose the 12SA7 is defective. We have a 6SA7 available, but no 12SA7. The 6SA7 filament requires .3 ampere, while the 12SA7 requires .15 ampere. This makes it impossible to install one series resistor to drop the voltage 6 volts, because of the different current requirements of the tubes. Now we know that if we connect tubes in parallel their current requirements add, so if we connect the 12SK7 and 12SQ7 filaments in parallel, we do two things. We increase the current requirements of the two tubes to .3 ampere and reduce the voltage requirements by 12 volts. The 35Z5 and 35L6 each require .15 ampere, so we connect them in parallel also, making their joint requirements 35 volts at .3 ampere, so the total requirements of our filament string is now 6 volts plus 12 volts plus 35 volts, or 53 volts and a current of .3 ampere. We subtract the 53 volts from 120 volts (the line voltage) and find we have 67 volts to be dropped by a series resistor. To find the value of this resistor, we use Ohm's Law  $R = E/I$  which gives us a value of 225 ohms for the series resistor. ( $67 \div .3 = 223$  so use a 225 ohm resistor).

Placement of the series resistor R is important. If the resistor is placed between the end of the filament string and the line, the plate supply voltage will be lowered. The resistor should be placed as shown in Fig. 2B. This resistor also develops considerable heat. It should be located in a spot removed from parts likely to be damaged by heat (electrolytic condensers) and at the same time have plenty of space around the resistor for air circulation. The resistor should have a power rating of at least 20 watts.

If a type 50L6 is burned out, we may substitute a 35L6 in the original line-up, by installing a

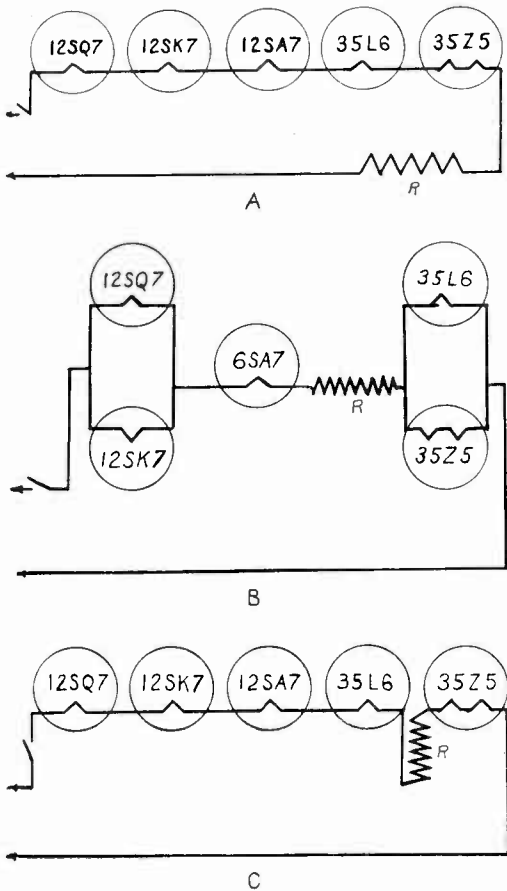

Fig. 2

series resistor whose value is determined by dividing the voltage drop desired by the current through the resistor or, in this case, 15 volts divided by .15 ampere or  $R = E/I$  or 100 ohms. The resistor should be capable of handling 10 watts, determined by use of the formula  $I^2R$  which is  $.15^2 \times 100$  or 9 watts. Use a 10-watt resistor as a minimum; a 20-watt would be better. While the resistor may be placed anywhere in the filament string, as far as the filament voltage is concerned, placing the resistor between the rectifier filament and the 35L6 filament will place the 35L6 farther down the string, which will decrease the difference in voltage between its filament and cathode, thus lowering the possibility of leakage developing between the filament and cathode. This is shown in Fig. 2C. Figure 3A shows a typical 6-tube filament string. Figure 3B shows wiring changes in the filament circuit which would allow the substitution of a 6SK7 for the 12SK7, and 6SA7 for the 12SA7. The series line resistor R should have 200 ohms resistance and carry (.3 ampere). The voltage drop across R should be 60 volts. The resistor should have a power rating of 20 watts or more.

Suppose only the 12SA7 is bad and we have a 6SA7 on hand for replacement use. Our problem now is to increase the current requirements of the filament string to .3 ampere. We can do this by connecting the 35Z5 and 35L6 in parallel. The 12SQ7 and 12SK7 are also connected in parallel. This leaves the 6SA7 and the 12SK7. We can increase the current drawn by the 12SK7 by shunting the filament with a resistor. The value of this resistor is determined by use of Ohm's Law. We divide 12.6 (the filament voltage) by .15 (the value of current which must flow through the shunt resistor). This gives us 85 ohms which is the required shunt resistance  $R_1$ . The resistor should be rated at 3 to 5 watts. Our filament string is now complete and its requirements are 35 volts, plus 12 volts, plus 12 volts, plus 6 volts or 65 volts at .3 ampere. We subtract this 65 volts from the 120-volt line voltage, which gives us 55 volts which must be dropped by a series resistor. Again we use Ohm's Law and divide 55 volts by .3 ampere and get 183 ohms which is the required series resistance R. Since 183 ohms is an odd value, use 185 ohms.

Figure 3C shows this schematically.

In substituting .3-ampere tubes for .15-ampere tubes it may be easier to change all the tubes in the radio to the .3 ampere type, adding a series resistance the value of which is determined by finding the voltage drop required across the resistor and dividing by the current drawn by one tube. If there is a supply of .3 ampere tubes available, this method is preferable. The .15 ampere tubes being retained in stock for straight replacement use.

While on the subject of tube substitution, a 12SR7

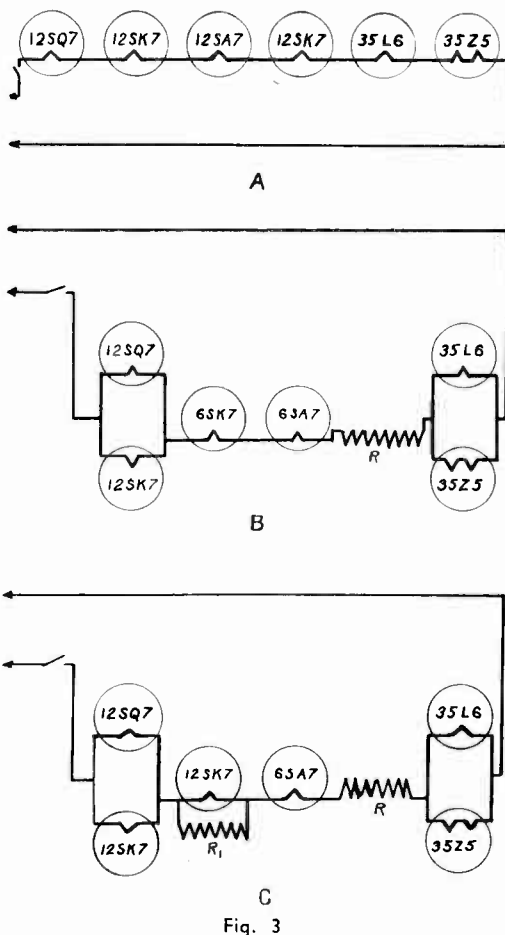

Fig. 3

may be substituted for a 12SQ7, directly with no wiring changes or circuit additions. No difference in operation will be noticed. When substituting tubes always refer to a tube guide to check the connections. Also make certain that the socket connections on unused pins are not used for "tie points" otherwise trouble may develop when the new tube is inserted in the socket.

The 25C6G can be substituted for the 25L6G provided there is room for the larger bulb of the 25C6G and the bias resistor is changed to about 210 ohms. In some cases, particularly the lower priced sets, substitution can be made directly without a noticeable change in output. In other cases the bias resistor must be changed.

The 50C6G can be substituted for the 50L6G, following the same method used with the 25C6G.

Here is an interesting sidelight concerning the

25C6G. While some cases of direct substitution will result in lowered output, a substitution of the 25L6G for a 25C6G will result in increased output. If you have a complaint of low output and the set uses a 25C6G output tube, substitute a 25L6G and the output will be increased.

So far I have not referred to tube substitutions which would require socket changes. At first thought a socket change does not seem to be very involved. However, when you stop to think of the way a socket is often buried under a blanket of condensers and resistors and the shortness of the connecting leads, a socket change often develops into a "major operation." In many cases it would be better to advise the owner to wait until tubes of the original type become available.

Where a socket change can be easily made the following tube types are interchangeable. A 7B7 for the 6S7G, the 7A7 for the 6SK7GT, the 7B8 for the 6ASGT, the single ended 6SA7GT for the 7Q7 and the duo-diode 6SQ7GT for the 7B6. All of these substitutions require a socket change.

In battery tubes the L in the type number indicates a lock-in mounting. The following types may be substituted but require a change in the socket type.

A 1A5G may be substituted for the 1LA4, the 1N5G for the 1LN5, the 1A7GT for the 1LA6 and the diode-triode 1H5GT for the 1LH4.

#### Rectifier Substitutes

The greatest danger in substituting rectifiers lies in not carefully considering the problems that will arise in substituting one type for another. The best rule, which should be followed whenever possible, when rectifier tubes must be changed is to replace a cathode type tube with a cathode type tube and a filament type tube with a filament type tube. After a substitution has been made it is very important to make certain that the voltage drop in the tube now being substituted is approximately the same as the tube type which was replaced, otherwise the voltage supplied to the filter condensers may be too high and exceed the safe rating of the filter condensers. With electrolytic condensers as difficult to obtain as they are at present, it may become a serious matter if they fail because of excessive voltage.

The substitution of a cathode type rectifier tube for a filament type rectifier tube invariably results in from 30 to 50 volts additional being available across the filters and means that the filter condensers will have to take this extra voltage. If they are already operating close to their maximum ratings, this will probably result in early filter condenser failure.

The substitution of filament type tubes for cathode type tubes will usually result in less voltage finally being applied across the filter condenser, because there is a greater voltage drop across the tube. This increased voltage drop is due to the difference in design. Another situation, however, will arise in connection with this type substitution which may be very serious. This comes about because the filament type tube heats up within two seconds, where the cathode type rectifier tube requires about nine seconds before the operating temperature reaches a value sufficient to permit normal operation of the tube. Most modern receivers employ cathode type output tubes which also require about nine seconds before they are ready to operate. When a combination of cathode type output tubes and cathode type rectifier tubes are employed, voltage is available across the filter when the output tube is ready to draw current so that the voltage across the filter condenser rises slowly. If, however, a fast heating filament type tube is substituted in place of the cathode type rectifier, then the rectifier tube will supply voltage to the filter after two seconds but the drain on the receiver will be practically nothing until nine seconds has elapsed. This means, therefore, that the voltage available across the filter system will be very high due to the fact that low current is being drawn. This voltage in extreme cases may become so high that every by-pass condenser in the receiver will be blown.

It is important to make certain that the voltage which is delivered to the filter before the output tubes are heated is low enough so that the filter condensers and other condensers in the equipment will not be destroyed. This has been taken care of in many receiver designs by supplying a self-regulating wet electrolytic condenser at the input to the filter. This type of condenser has a property of having extremely high leakage when the voltage exceeds its rating and this leakage returns to normal value when the voltage returns to its rated value.

This is a good place to point out also that when the first section of a filter condenser is replaced, the condenser should be replaced with one of the same type since otherwise the leakage characteristic may result in unexpected surges which may cause permanent damage to condensers in other parts of the circuit.

Lamp bulbs may be used to replace line cord resistors. The current rating of a lamp bulb may be determined by moving the decimal point two places to the left. A 75-watt bulb will pass .75 ampere. A 40-watt bulb or two 25-watt bulbs in parallel would be satisfactory for the average set using .3-ampere tubes. When the set is first turned on the lamp will glow to almost full brilliancy then as the tube filaments warm up the lamp will dim. The lamp bulb also develops

quite a bit of heat and should be placed so this heat will not prove harmful to receiver parts.

Condensers of the mica type are not to be had except in rare instances. However, the type dielectric is not so important so long as the condenser has the correct capacity and working voltage.

In replacing fixed condensers be guided by the service diagram for the correct value to use; the capacity on the condenser label or case put on by the condenser manufacturer is a sufficient guide. If no service diagram is available, use: .1 to .25 mfd. for r.f. and i.f. by-passes; .25 to 1 mfd. for a.f. by-pass; 1 to 10 mfd. for C bias resistor shunt capacities in a.f. circuits; .00025 mfd. for grid leak detectors; .0001 mfd. for r.f. coupling condensers; .01 to .25 mfd. for a.f. coupling condensers.

Remember, a .002 mfd. paper condenser will behave exactly the same as far as capacity is concerned as a .002 mfd. mica condenser. The exact capacity value need not be followed. Variations in capacity of 10% (except in one case, that of superheterodyne oscillator circuits) are of no importance.

The voltage rating of a condenser is very important. If you are in doubt as to the correct voltage rating, measure the voltage across the terminals where the condenser is to be connected. The condenser's voltage rating should be greater than this value. It is a good idea to never use a fixed condenser of less than 600 volt rating even if the condenser is to be used in a low voltage circuit. Buffer condensers in vibrator power supplies should be rated at 1600 volts or more. Filter condensers of the paper type should have a 600 volt rating. These are excellent rules to follow at any time but, are doubly important with the parts situation we are faced with.

The electrolytic condenser presents problems somewhat different from those found in the paper type because an electrolytic condenser has polarity and cannot be used on a.c.

Electrolytic condensers too are rated as to capacity and working voltage. For use in filter circuits the most common sizes are 4 and 8 mfd., although smaller and larger sizes are used in many receivers.

The Instruction Department receives many requests from students in which they state, "This receiver has a 10-mfd., 475-volt filter condenser which is shorted and I cannot secure a replacement. What can I do?" The answer is simple. Use an 8 or 12 or 16-mfd., 475-volt condenser. In all probability no difference in hum level will be noticed when an 8-mfd. unit is used to replace a 10-mfd. unit.

A.F. by-pass condensers are often of the dry electrolytic type. As the required voltage rating is low, and the capacity high, a small compact unit is available. Units of 10, 25 or 50 microfarads with 25 to 75 volt ratings are used. For filtering rectified A power, 15-volt, 1000 or 2000-microfarad dry electrolytics are used.

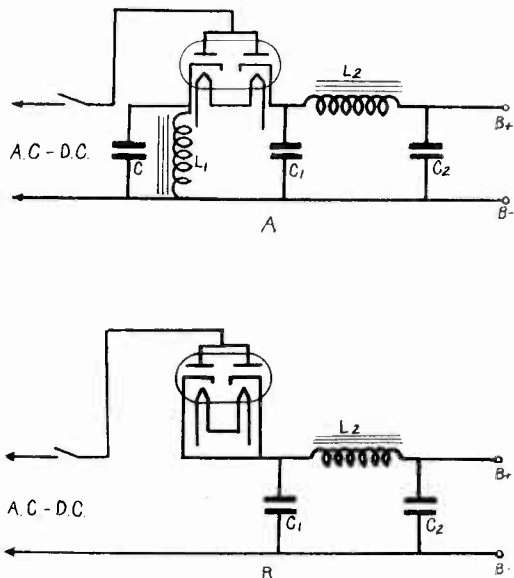

Fig. 4

Figure 4 shows one method used to obtain field excitation in transformerless power supplies.  $L_1$  is the speaker field coil and  $L_2$  is the filter choke. Suppose the field coil opens and you cannot obtain a replacement field or a similar loud speaker—what can be done?

A permanent magnet-type dynamic speaker may be substituted by changing the cathode connection as shown in Fig. 4B.

If the speaker field coil was used as a choke in place of  $L_2$  in Fig. 4A, a permanent magnet-type speaker may be employed and a filter choke substituted for the speaker field.

Should the rectifier cathode, supplying the speaker field in Fig 4A, open all that is necessary is to connect a jumper between  $L_1$  and the other cathode. The condenser C should be disconnected when this is done. Many servicemen disconnect C and tie both cathodes together, when they service a set of this type, as a matter of routine.

A resistor may be used to take the place of a speaker field or choke in a.c.-d.c. sets as shown

in Fig. 5. The resistor should have a value of 3000 ohms if it is to be effective in reducing the ripple. Even then, higher capacity filter condensers may be required. If the input filter condenser is made greater than 20 mfd. insert a 25-ohm resistor in series with the rectifier plate to protect the tube against peak current surges.

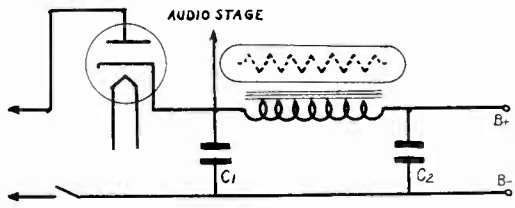

Fig. 5

By replacing a 200 or 300-ohm choke with a 3000-ohm resistor the voltage drop across the resistor will increase, leaving less voltage for operation of the receiver. To avoid this loss in voltage the current through the filter resistor is decreased, thereby reducing the voltage drop across it and increasing the voltage available for the receiver circuits.

The power tube plate supply must be taken from the rectifier tube cathode in order to reduce the voltage drop across the resistor. A resistor used in place of the choke will not cause excessive hum because the ratio of  $I_a$  to  $C_2$  determines the amount of ripple and if the reactance of the choke is 3000 ohms for instance, then the ripple voltage will be no greater if a 3000-ohm resistor is substituted for  $L_1$ . The higher the resistance of a resistor used in a filter, the better the filtering action, but the voltage drop across the resistor will be greater. The screen voltage should be taken from the output of the filter system as hum voltage applied to the screen will be amplified.

Opens in the primaries of audio transformers are also a common source of trouble. Quite often, impedance coupling can be used with very little decrease in audio gain to replace a circuit such as 6A. This is shown in Fig. 6B. C may be any value between .01 to .25 mfd. Experiment with different values to arrive at the capacity best suited. The value of R should be high with respect to the plate resistance of the tube if the stage gain is to approach the  $\mu$  of the tube. Values between 50,000 and 100,000 ohms will usually be satisfactory in the case of triode tubes. Experiment with different values to obtain the greatest volume with the least distortion.

If the secondary of the transformer should open, the method shown in Fig. 6C may be followed. C has a value of .01 to .25 mfd., while R should be about 500,000 ohms or more. In the case of

a pentode tube, the value should be decreased to around 100,000 ohms, because of the presence of gas in pentode tubes and the fact that they draw grid current. With a high value of grid resistance, grid current due to gas will produce a voltage across the grid resistor which will reduce the bias, causing distortion and reducing the life of the tube.

Where the whole transformer is in need of replacement, straight resistance coupling may be used at considerable loss in gain. Usually, resistance coupling is not satisfactory replacement for transformer coupling due to these losses.

For push-pull stages, an open primary may be handled as shown in Fig. 6D. However, this method should only be used when no transformer can be obtained.

An intermediate frequency transformer may develop an open in one of its windings. Figure 7 shows a method by which the set may be repaired if no suitable replacement is at hand. The coil  $L_1$  is the plate winding or input of the transformer. If this coil becomes open, it may be replaced by an r.f. choke of 60 to 80 millihenrys, as shown in Fig. 7B. This coil is untuned, so  $C_1$  is disconnected from the circuit. If the choke cannot be so placed as to provide inductive coupling, a small capacity may be connected as shown by the dotted lines. This capacity may be formed by twisting together two short lengths of insulated hook-up wire. The gain of an i.f. stage using choke type coupling will be greater than the gain with a double-tuned transformer. However, the selectivity will be considerably less.

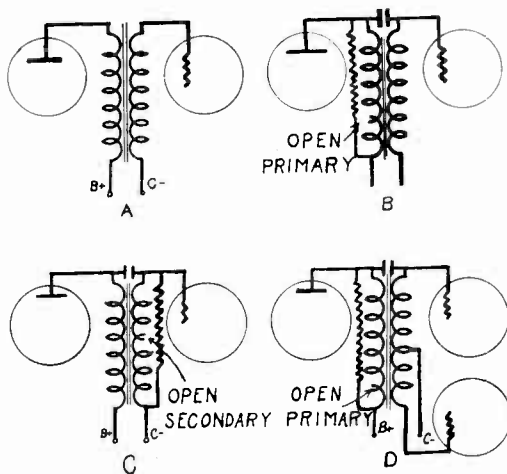

Fig. 6



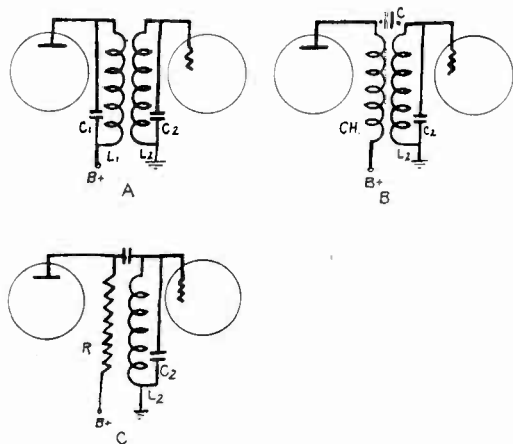

Fig. 7

A resistor may also be substituted for the open primary, as shown in Fig. 7C. The resistor should, if possible, have a value approaching the tube's plate resistance (practical values are between 100,000 and 250,000 ohms).

#### Noisy Volume Or Tone Controls

Without a doubt the best policy in service work is to replace faulty volume or tone controls. They do not hold up for any considerable length of time after being cleaned or repaired. However, when the correct replacement is not available, the control must be repaired as well as possible to obtain further use from it.

Noisy tone controls can be "touched up" by applying carbon to the worn, noisy spots. For this purpose "Carbon X" a special compound is useful and is easily applied. It comes in convenient small bottles. It is often possible to fill in one spot with carbon from an ordinary lead pencil, but this is a highly unsatisfactory method, suitable only as a temporary measure.

There are several combination cleaners and lubricants for noisy wire-wound volume controls available. "Energine" and "Carbona" are excellent home cleaning fluids and are also excellent cleaners for contacts. Powdered graphite mixed thoroughly with white uncarbolated vaseline which is obtainable at any drug store can be used as a home-made lubricant to be applied after a thorough cleaning.

Another cleaning and lubricating solution can be made of two ounces of "Carbona" and one-half level teaspoon of white uncarbolated vaseline. Shake well and let it stand overnight. Apply the mixture with a stiff toothbrush to the contacts to be cleaned. Then wipe over the contacts with a clean finger. Very often quite an

improvement in noisy contacts of volume or tone controls results from a simple cleaning and lubricating with such solutions.

Quite often a set not of standard manufacture requires a new volume or tone control and no information is available as to the correct value. Physical size of a replacement control in these sets may or may not be important. The replacement, must however, be small enough to fit in the available space, but large enough to carry the necessary current. The shaft diameter and length should be such that the unit works satisfactorily when installed. The total resistance of a tone control can be measured with an ohmmeter. If the original control was open, the total value can be found by measuring the resistance on each side of the open and then adding the two values.

Controls below 10,000 ohms are usually of the wire-wound type.

To harden "soft" speaker cones, spray several times with a thin, clear lacquer, using a spray gun. A hand sprayer is satisfactory. This can be done without removing the cone from the speaker, if you will cover the center opening of the dynamic with a cloth pad. Better results are obtained, however, if the cone is first removed and both sides sprayed evenly. Do not use more lacquer than the cone material readily absorbs and wipe off any excess before it sets. Allow at least ten hours drying time before attempting to center the cone or use the speaker. This treatment is also effective on old types of dynamics where the cone is made of cloth, such as the early Victors and Philcos, and where the trouble is so often due to vibration and humidity. This type trouble can be recognized by the fact the higher frequencies will be missing and speech will sound "mushy." When this defect appears, the simple lacquer treatment makes cone replacement unnecessary.

— n r i —

## OUR COVER PHOTOGRAPH

Through the courtesy of the Post and Lester Co., Hartford, Conn., we show a section of the R.C.A. Sound Laboratories, with N.R.I. graduate Gerald A. Miller at the bench.

The Post and Lester Co. has a high grade staff of engineers and does practically all the sound work for the State of Connecticut. At last writing Mr. Miller and the firm he represents were making a survey with a view of installing Sound equipment in a large plant in Waterbury, Conn. involving some one hundred and thirty buildings.

In the laboratory, part of which is pictured on our cover, all sound equipment is first checked before being installed. Here also new methods and circuits are designed.

# Sample Questions and Answers for Radio Operator License Examinations

By WM. FRANKLIN COOK

N. R. I. Technical Consultant



**T**HIS is another installment of the questions taken from the "Study Guide and Reference Material for Commercial Radio Operator Examinations," together with typical answers. The questions give a general idea of the scope of the commercial radio operator examinations.

The basic theory for these questions has been covered in your Course, but is being repeated here as answers to these questions. Remember, the following answers are far more detailed than would be required for an operator's license examination. The questions are theoretical, so the answers go more thoroughly into the basic theory, in order to permit similar questions to be answered.

Some of the material is advanced technical data, of course, which can be properly understood only by the advanced student or graduate. However, you will find this information valuable, whether or not you intend to take the operator's license examination.

## ELEMENT II

### Basic Theory and Practice

**(2-185) What is the chemical composition of the active material composing the positive plate of a lead-acid type cell?**

*Ans.* In preparing the positive plate of a lead-acid storage cell, a paste of litharge and lead peroxide is prepared using dilute sulphuric acid as the liquid material. This is pressed into the perforations of the grids in

the same manner the negative plate is prepared.

After pasting, the plate is subjected to an electro-chemical process which changes the paste to lead dioxide ( $PbO_2$ ). This is some times called lead peroxide.

**(2-186) How does a primary cell differ from a secondary cell?**

*Ans.* The principal difference between a primary cell and a secondary cell is that the active material of a primary cell is used up as current is drawn from the cell. In the secondary cell there is a chemical change brought about in the active materials of the cell as current is drawn from it. By reversing this chemical change the secondary cell is renewed (recharged). The primary cell cannot be recharged for its active materials have been used up.

**(2-187) What is the chemical composition of the active material composing the positive plate of an Edison type storage cell?**

*Ans.* The active material on the positive grid of an Edison "alkali" cell is nickelous hydroxide,  $Ni(OH)_2$ , and exceedingly thin flakes of pure nickel. This material is pressed on the positive grid in over 600 alternate layers by a hydraulic hammer process.

**(2-188) What is the chemical composition of the electrolyte used in an Edison type storage cell?**

*Ans.* The electrolyte used in the Edison cell is a solution of potassium hydroxide (KOH), and water with a small amount of lithium hydroxide (LiOH).

**(2-189) What is the chemical composition of the electrolyte of a lead-acid storage cell?**

*Ans.* The electrolyte of a lead-acid type storage cell consists of pure sulphuric acid (about 20%) and chemically pure (distilled) water, (usually about 80%). The specific gravity of such a solution when the cell is fully charged will vary between 1.275 and 1.300 depending on the temperature.

**(2-190) Why is a 45-volt, dry cell "B" battery generally considered unsatisfactory for use when the terminal voltage has fallen to approximately 36 volts?**

*Ans.* The internal resistance of a primary cell increases as the cell discharges. When the internal resistance of a cell gets so high that the battery becomes noisy and erratic in operation, it is considered unsatisfactory and should be replaced. The terminal voltage of the battery when this condition is reached is usually 20% below its normal terminal voltage when full load current is being supplied.

**(2-191) What is "polarization" as applied to a primary cell and how may its effect be counteracted?**

*Ans.* "Polarization" is the name applied to the formation of hydrogen bubbles on the surface of the positive electrode of a cell. The hydrogen bubbles insulate the electrode from the electrolyte, which increases the resistance between the positive plate and the electrolyte. This increased cell resistance decreases the terminal voltage, under load, so the battery supplies less power. Depolarizing chemicals are used to absorb the hydrogen, thus reducing the polarizing effects.

**(2-192) Describe three causes of a decrease in capacity of an Edison-type storage cell?**

*Ans.* The only causes of permanent reductions in capacity in the Edison cell are: the result of excessive temperatures (above 120 degrees); aging of the electrolyte; or internal defects such as shorted plates caused by impure water or defective insulation.

The capacity of an Edison cell can be temporarily reduced by cold; allowing the battery to stand idle for long periods; operation at very low rates for long periods. Raising the temperature, or several repeated charg-

ing and discharging cycles at a high rate will restore the capacity to normal in these cases.

**(2-193) What is the cause of heat developed within a storage cell under charge or discharge condition?**

*Ans.* A violent chemical action takes place in a cell when the cell is either charging or discharging. This chemical action is between the electrodes and the electrolyte, and produces heat. If the charging is carried on at too high a rate or the cell is discharged too rapidly, this heat developed may permanently damage the cell components.

**(2-194) How should sulphuric acid and water be mixed, if it becomes necessary to do so in order to replace lost electrolyte?**

*Ans.* The distilled water should be placed in a glass or earthenware container and while the water is being stirred with a non-metallic paddle the acid should be slowly added to the water in small quantities. The acid and water should only be mixed out of doors or in a well ventilated room free from flames. *NEVER ADD water to the acid* as a very violent explosion may occur.

**(2-195) How may a dry cell be tested to determine its condition?**

*Ans.* By measuring the cell voltage, while the cell is connected to a load. This load may be anywhere between 50% of the rated current capacity and full load.

**(2-196) What the result of discharging a lead-acid storage cell at an excessively high current rate?**

*Ans.* Discharging produces heat, so an excessive rate will overheat the cell. The excess heat may cause destruction of the plates, depending on the rate and time of discharge.

**(2-197) What is the approximate fully charged voltage of an Edison storage cell?**

*Ans.* The approximate full-charge voltage of an Edison cell is 1.2 volts per cell.

**(2-198) A 6-volt storage battery has an internal resistance of 0.01 ohm. What current will flow when a 3-watt, 6-volt lamp is connected?**

*Ans.* The internal resistance of the storage battery is so small that compared to the resistance of the lamp, it may be neglected. Ohm's Law for power is then applied as follows:  $I = W \div E$ , so  $3 \div 6 = .5$  ampere. Where the battery resistance must be con-

sidered, find the lamp resistance from  $R = E^2 \div W$ , which gives  $36 \div 3 = 12$  ohms. Then add the battery resistance to this, giving 12.01 ohms. Now the current is  $E \div R$ , or  $6 \div 12.01$ , which gives .499 ampere. This is so close to .5 ampere we would never be able to tell the difference except by calculation.

**(2-199) What is the approximate fully-charged voltage of a lead-acid cell?**

*Ans.* The approximate fully-charged voltage of a lead-acid cell is 2.1 volts.

**(2-200) Why is low internal resistance desirable in a storage cell?**

*Ans.* Low internal resistance is desirable for high output current and is an aid in voltage regulation. If the battery resistance is appreciable the circuit current will produce a voltage drop, so the battery voltage decreases when a load is applied. Hence, the amount of resistance determines how much power we can get from the battery. The lower the resistance, the greater the power output.

**(2-201) What is "local action" and how may its effects be counteracted?**

*Ans.* Any impurities in a cell permit a chemical action within a battery cell, causing an internal current flow between elements. Since this action occurs in small sections of the cell, it is known as "local action." Local action increases the cell's internal resistance, and in so doing decreases the efficiency. The only way to prevent local action is to utilize chemically pure elements in the construction of the cell and then prevent any impurities from entering after the cell is manufactured. Only distilled water should be used in a cell. If local action is strong the cell will be discharged in a short time. Frequent recharging, or a continuous "trickle charge" at a very slow rate will counteract this discharging.

**(2-202) What is meant by the term "sulphation" as applied to a lead-acid storage cell?**

*Ans.* Sulphation is the term applied to the results of the chemical action in a lead-acid storage cell. The sulphuric acid molecules of the electrolyte break up and combine with the lead of the plates, forming lead sulphate, as the battery is discharged. When recharged, sulphate is broken up and the original materials restored. The sulphate fills the pores of the plates, preventing proper contact between electrolyte and active chemi-

icals. When a cell is sulphated, its output is greatly reduced. Recharging restores the cell to normal, however, if the sulphation is not excessive.

**(2-203) How may the condition of charge of the Edison cell best be determined?**

*Ans.* The state of charge of a nickel-iron-alkali cell should be determined by measurement with a low resistance voltmeter or measurement of the voltage of a cell while it is under normal load. The electrolyte of this type cell undergoes a very slight change during charge or discharge; therefore, a hydrometer is useless for testing one of these cells.

**(2-204) If the charging current through a storage battery is maintained at a normal rate, but its polarity is reversed, what will result?**

*Ans.* If the battery were a lead-acid battery, excessive heating, evaporation and loss of electrolyte, and severe buckling of the plates would result from attempting to charge the battery with reversed polarity. This may ruin the battery. If the battery were a nickel-iron-alkali (Edison) battery, no damage would be done other than a possible reforming of the electrodes at reversed polarity. This can be corrected by proper charging.

**(2-205) What are the effects of sulphation?**

*Ans.* Lead sulphate is formed on the plates of a cell during discharge. When the cell is being charged, this sulphate is forced back into the electrolyte. If the charging process is stopped before all the lead sulphate is driven off, a residue will remain. While the battery is being discharged on the next cycle, this residue will be added to by the newly formed deposit of sulphate. Each time the battery is recharged this amount increases. The result is an excessive amount of sulphate of lead on the surface of the plate, which will reduce the capacity of the battery and can eventually destroy it by pushing the active materials out of the grids and buckling the plates, as it is of greater bulk than the original chemicals. Over-discharging, allowing the battery to stand discharged and adding acid to the battery unnecessarily cause excess sulphation. Complete and full charging will clear up this condition if no damage has occurred.

**(2-206) How may the state of charge of a lead-acid storage cell be determined?**

*Ans.* The state of charge of a lead-acid

storage cell is best determined by using a hydrometer to indicate the specific gravity of the electrolyte. The sulphuric ions combine with the plates on discharge, thus changing the specific gravity. The charge restores the electrolyte to normal which is also indicated. Measuring voltage, even under load is a poor test, as the voltage drop is not proportional to the state of charge.

**(2-207) With respect with its use in connection with d.c. motors and generators, what is the meaning of the term "neutral position"?**

*Ans.* The neutral position is the position where the armature current reverses and a minimum voltage difference exists between adjacent commutator segments. The brushes short adjacent segments when the armature is rotating, as by placing them in the neutral position, minimum sparking occurs. When the current in the armature is zero the neutral position is half way between the two adjacent field poles. When current is flowing, the neutral position moves forward in the generator in the direction of rotation; in a motor, the neutral position is moved backward from the direction of rotation.

**(2-208) Why is laminated iron or steel generally used in the construction of a field or armature cores of motors and generators instead of solid metal?**

*Ans.* Laminations are used to reduce eddy currents, as in transformer cores also. If solid cores were used, heat would be developed by eddy currents, which would be a direct power loss.

**(2-209) What is meant by "regulation" of a generator?**

*Ans.* As there is always some resistance in the armature, there will be a voltage drop whenever current is taken from the generator. The smaller the resistance, the less the difference between the no-load and the full-load terminal voltage and the better the regulation. For generators, regulation is usually expressed as a percentage of the full-load voltage. The formula is:

$$\frac{\text{no-load voltage} - \text{full-load voltage}}{\text{full-load voltage}} \times 100.$$

**(2-210) What is the purpose of "commutating poles" or "interpoles" in a d.c. motor?**

*Ans.* Commutating poles or interpoles are small poles located between the main field poles in a d.c. motor. The windings on these poles are in series with the armature. These poles are placed in the neutral position so that their fields oppose the self-induction of

the armature, driving the armature current to zero. The brushes are then placed at this point, so that minimum sparking occurs. These poles are particularly helpful on reversible motors, where a change in direction would call for a shift in brush position ordinarily. However, the interpoles reverse automatically, always providing the same neutral position.

**(2-211) How may the output voltage of a separately excited a.c. generator, at constant output frequency, be varied?**

*Ans.* The strength of the field and the speed of rotation determines the output voltage of a separately excited a.c. generator. Since the speed of rotation is used to determine the output frequency, any change in speed would cause a change in output frequency. The only means left is to vary the strength of the field either by means of a field rheostat or by adjusting the excitation being delivered by the exciting source.

**(2-212) If the field of a shunt-wound d.c. motor were opened while the machine was running under no load, what would be the probable result (s)?**

*Ans.* If the field of a shunt-wound motor opens while the machine is running, the counter e.m.f. ordinarily generated in the armature by the field, disappears with the result that the machine will "run away" and damage itself by its excessive speed.

**(2-213) Name four causes of excessive sparking at the brushes of a d.c. motor or generator.**

*Ans.* Excessive sparking at the brushes of a d.c. motor or generator may be due to the generator being overloaded, dirty brushes or commutator, improper brush adjustment, brushes not shaped to fit the commutator, an open armature circuit, the brushes off the neutral point, too rapid starting, or a high commutator bar.

**(2-214) What is the purpose of a commutator on a d.c. motor? On a d.c. generator?**

*Ans.* When used on a d.c. motor the commutator serves as a mechanical means to reverse the input applied to the armature in such a direction as to enable the motor to rotate. Otherwise, it would try to reverse direction as the armature coil moved from one pole to the next, as the magnetic field reverses, so the current flow must reverse to maintain the same direction of rotation. On a generator, the commutator serves to periodically reverse the polarity of the generated voltage. It acts as a mechanical rectifier, changing the generated a.c. to d.c.

# Novel Radio Items

—BY W. R. MOODY—

**Photoelectric instruments**, being developed by Westinghouse engineers, monitor the color of the blood in a flier's ear and indicate when additional oxygen is needed during high-altitude flying. The arrangement is based upon the change in the color of the blood with changes in oxygen content. A tiny light and midget phototube are supported on opposite sides of the ear lobe by a spring clip, and the electrical voltage output of the phototube is amplified and fed to an indicating instrument.

— n r i —

**An electronic method** of determining moderate intoxication at the time of an accident or arrest has been developed at Yale University. The device requires only a sample of expired air and gives a result in terms of alcohol concentration in a few minutes.

— n r i —

**At a Royal Naval Air Station** in South England, Personnel of the Women's Royal Naval Service are expert radio mechanics and, in addition to installing transmitters in planes, the girls are taught to operate radio instruments of various kinds.

— n r i —

**Although amateur radio operation** has been prohibited for the duration, many amateur operators are back on the air again as war emergency workers. They are supplementing regular communications facilities in the event of air raids and are aiding in the event of other disasters. A new service enables communities throughout the country to set up, at their own expense, mobile, portable and fixed short-wave communications on a two-way basis. This branch of service has been given the name WERS, standing for War Emergency Radio Service.

— n r i —

**The Norwegian Government** has taken over several large houses and transformed them into business-like workshops in England. The houses are fitted with ships' engines and radio equipment. Norwegian seamen, arriving in England, are trained to become radio operators and engineers. The training courses last from three to eight months.

Page Fourteen

**The oscillograph** has been put to use at the University of Rochester School of Medicine to record the factors considered essential to the process of walking. Pressure responsive resistance discs, each about the size of a dime, are applied to six points on the bottom of each foot and are connected to the high sensitivity apparatus. By comparing and analyzing nearly 4,000 charts of normal and abnormal walking, time and pressure values for normal walking have been formulated. Comparison of the normal values with the values obtained with patients under treatment allow a positive check on the effectiveness of the medical treatment. The oscillograph has also been applied to the recording of muscle action, the data obtained being useful in the study of certain physical ailments, such as infantile paralysis. Progress has been made in this field using this electronic equipment.

— n r i —

**With twenty-two short-wave transmitters** under construction, the United States will by next March have a total of thirty-six stations bringing the facts of America's war aims and gains to the people of all enemy and enemy-occupied countries, and to the rest of the world, according to Roy C. Cordeman, Assistant Chief of the OWI Bureau of Communications facilities.

— n r i —

**On the basis of normal civilian production** of radio equipment, it would take more than 150 years to produce the \$4,300,000,000 output of military radio equipment in 1943, according to Frank H. McIntosh, Assistant to the Director of WPB's Radio and Radar Division. In transmitter manufacture alone, war needs have boosted output from a normal \$3,500,000 per year to the present figure of approximately \$300,000,000 per year.

— n r i —

**Direct contact with aircraft** during the training of pilots for the fleet air arm is conducted by tricycle wireless telegraph stations maintained by members of the British Naval Radio Unit. By means of such contact the faults of the pilot trainees can be pointed out to them immediately.

# POSTAL DELIVERY ZONE NUMBERS

By GORDON BIRREL

N. R. I. Office Manager

Notice the 9 after Washington and before D. C. in the "box" above. That 9 is the Institute's postal *delivery zone number* and should be used whenever you address a letter or lesson to the Institute.

If you are one of the 42,450,807 people (more or less) living in the 124 big U. S. cities listed below, you too have a postal *delivery zone number* which belongs in your correct mailing address. If you have not already learned what this number is, you can get it by asking your mail carrier or by inquiring at your Post Office.

The Post Office Department is introducing this delivery zone numbering system to speed the sorting of mail. Mail which fails to show this zone number will be delayed in delivery.

National Radio Institute

1536 U St., N. W.

Washington 9, D. C.

This number should appear immediately after the name of the *city*, and should be followed by the name of the State. The only exception is in the case of organizations, such as the National Radio Institute, which have many thousands of names and addresses on stencils or plates. To conserve these stencils and avoid waste we are allowed to add the zone number after the name of the state. In all other cases it should follow directly after the name of the city.

We are anxious to get and use every student's and every graduate's postal delivery zone number so we can show it on his mail and speed our service to him. So we say *learn your postal delivery zone number*. Learn those of the people and the business establishments to whom you write. Use these numbers to help the Post Office speed the U. S. Mails.

## List of 124 U. S. Cities Using Postal Delivery Zone Numbers

Birmingham, Ala.  
Mobile, Ala.  
Montgomery, Ala.  
Berkeley, Calif.  
Fresno, Calif.  
Glendale, Calif.  
Long Beach, Calif.  
Los Angeles, Calif.  
Oakland, Calif.  
Pasadena, Calif.  
Sacramento, Calif.  
San Diego, Calif.  
San Francisco, Calif.  
San Jose, Calif.  
Stockton, Calif.  
Denver, Colo.  
Bridgeport, Conn.  
Hartford, Conn.  
New Haven, Conn.  
Waterbury, Conn.  
Wilmington, Del.  
Washington, D. C.  
Jacksonville, Fla.  
Miami, Fla.  
Saint Petersburg, Fla.  
Tampa, Fla.  
Atlanta, Ga.  
Honolulu, T. H.  
Chicago, Ill.  
Decatur, Ill.  
Peoria, Ill.

Evansville, Ind.  
Fort Wayne, Ind.  
Indianapolis, Ind.  
South Bend, Ind.  
Des Moines, Iowa  
Sioux City, Iowa  
Kansas City, Kans.  
Wichita, Kans.  
Lexington, Ky.  
Louisville, Ky.  
Alexandria, La.  
Baton Rouge, La.  
New Orleans, La.  
Shreveport, La.  
Portland, Maine  
Baltimore, Md.  
Boston, Mass.  
Brookton, Mass.  
Springfield, Mass.  
Worcester, Mass.  
Detroit, Mich.  
Flint, Mich.  
Grand Rapids, Mich.  
Kalamazoo, Mich.  
Lansing, Mich.  
Pontiac, Mich.  
Duluth, Minn.  
Minneapolis, Minn.  
Saint Paul, Minn.  
Jackson, Miss.  
Kansas City, Mo.

Saint Joseph, Mo.  
Saint Louis, Mo.  
Lincoln, Nebr.  
Omaha, Nebr.  
Elizabeth, N. J.  
Jersey City, N. J.  
Newark, N. J.  
Paterson, N. J.  
Trenton, N. J.  
Albany, N. Y.  
Brooklyn, N. Y.  
Buffalo, N. Y.  
Jamaica, N. Y.  
Long Island City, N. Y.  
New York, N. Y.  
Rochester, N. Y.  
Schenectady, N. Y.  
Staten Island, N. Y.  
Syracuse, N. Y.  
Utica, N. Y.  
Yonkers, N. Y.  
Charlotte, N. C.  
Winston-Salem, N. C.  
Akron, Ohio  
Canton, Ohio  
Cincinnati, Ohio  
Cleveland, Ohio  
Columbus, Ohio  
Dayton, Ohio  
Toledo, Ohio  
Youngstown, Ohio

Oklahoma City, Okla.  
Tulsa, Okla.  
Portland, Oreg.  
Philadelphia, Pa.  
Pittsburgh, Pa.  
Scranton, Pa.  
Williamsport, Pa.  
San Juan, P. R.  
Providence, R. I.  
Charleston, S. C.  
Columbia, S. C.  
Chattanooga, Tenn.  
Knoxville, Tenn.  
Memphis, Tenn.  
Nashville, Tenn.  
Austin, Tex.  
Dallas, Tex.  
Fort Worth, Tex.  
Houston, Tex.  
San Antonio, Tex.  
Salt Lake City, Utah  
Norfolk, Va.  
Richmond, Va.  
Roanoke, Va.  
Seattle, Wash.  
Spokane, Wash.  
Tacoma, Wash.  
Charleston, W. Va.  
Huntington, W. Va.  
Madison, Wis.  
Milwaukee, Wis.

# OHMMETERS AND HOW TO USE THEM

By **RAYMOND SCHAAF**

W9KVG/3  
N. R. I. Consultant



**S**UCCESSFUL servicing isn't all brain work. Hundreds of times each day even experienced servicemen use certain electrical test instruments to substantiate their deductions. One of the instruments they use is an "ohmmeter."

Briefly, an ohmmeter is a device used to measure electrical resistance. A measurement of resistance will disclose when parts or circuits are; (a) "open" so that direct current cannot flow through them, (b) "short-circuited" so that they no longer offer their normal amount of resistance to the flow of current, and (c) "grounded" so that current is by-passed around them and thus cause them to fail to operate as they should. If the measurement of resistance can tell so much about circuits and parts it is important that the serviceman know how to use to the best advantage the instruments normally employed for this work.

#### *Four Ways to Measure Resistance*

The four basic methods of measuring resistance are as follows; (a) Voltmeter (b) Voltmeter-Ammeter (c) Wheatstone Bridge and (d) Ohmmeter. The first three methods named are considered too slow for service work for they make it necessary to take meter readings and then "figure out" the resistance by using a formula. On the other hand, an ohmmeter indicates the resistance instantly. Its indicating meter is calibrated to read directly in ohms. Because of its speed and convenience the ohmmeter is the principal method now used by servicemen for the measurement of resistance.

#### *Series Type Ohmmeter Circuit*

The simplest ohmmeter possible consists of a

Page Sixteen

milliammeter, a battery and pair of test leads arranged to form a series circuit which will include the part or circuit being tested. Such an arrangement is shown in Fig. 1. A typical scale is illustrated in Fig. 2. Note that the scale is calibrated to read ohms even though it is basically a direct current milliammeter.

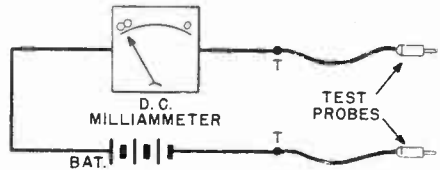

Fig. 1 Series-type Ohmmeter

The theory of operation is that the battery voltage is just sufficient to give full-scale deflection when the test leads are held together thus simulating the lowest possible resistance (zero) value. When the test leads are connected to any part or circuit having electrical resistance, the pointer deflection is less than full-scale by an amount proportional to the resistance connected to the test leads. Should the part or circuit be "open" so that current from the ohmmeter battery cannot flow, the meter pointer will of course remain in its normal position at the left side of the meter scale.

#### *Shunt Type Ohmmeter*

The series type ohmmeter just described is best adapted to the measurement of medium and high resistance values. However, it is sometimes necessary to measure very low resistance (low voltage power transformer windings for instance). This can be done with reasonable ac-



curacy by connecting the resistance to be measured across the meter instead of in series with it. Such an arrangement is shown in Fig. 3. Note that the same battery, test leads and meter are used. This time, however, the meter scale is quite different.

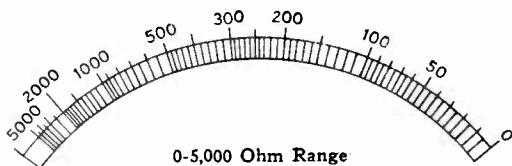

Fig. 2 Typical Series-type Scale

The theory of operation is as follows. The battery voltage is again adjusted to give full scale deflection but this time full-scale deflection is obtained with terminals T-T open-circuited. When the test leads are held together to simulate zero resistance all the circuit current is by-passed around the meter and its pointer remains at the left of the scale. Thus "zero" is at the left and high resistance readings are at the right of the scale just as on the sample scale shown in Fig. 4.

When resistance is connected to terminals T-T, part of the circuit current goes through the resistance and part through the meter. The meter deflection is governed by the amount of current through it and is therefore proportional to the amount of resistance being measured for this is what determines how much current goes through the meter.

#### Maintaining Calibration

Unless some means is used to compensate for the drop in battery voltage as the instrument is used, the meter will no longer read full scale (or zero at the left in the case of a shunt type ohmmeter) when the test leads are held together. The way of correcting this is to purposely make the battery voltage high and insert a variable resistance in series so that as the battery ages, the circuit resistance can be made less and thus restore the current to the normal value. Such an adjustment is usually called the "zero-ohms" adjustment.

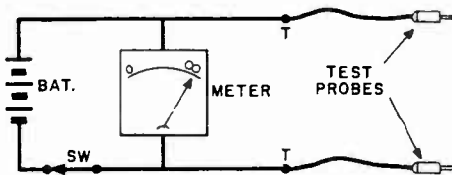

Fig. 3 Basic Shunt Ohmmeter Circuit

#### Need for Different Ranges

Modern receivers and electronic control equipment contain resistance ranging from a fraction of 1 ohm to 10 or 20 megohms. While it is theoretically possible to measure any value of resistance from zero to infinity (open circuit) with the simple circuit of Fig. 1; practically it can't be done with any degree of accuracy. Several different ranges are usually provided so that no matter what the value being measured, there will be a range available on which approximately mid-scale deflection and thus good accuracy will be obtained.

To avoid placing a number of scales on one meter, the ohmmeter may be designed so that the various ranges are a multiple of the basic range for which the meter is calibrated.

Having discussed briefly the two basic types of ohmmeters, let us now learn how to use them to the best advantage.

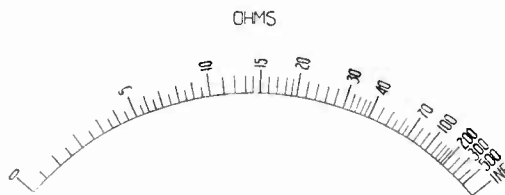

Fig. 4 Typical Scale of Shunt Ohmmeter

#### Two Basic Causes of Trouble

Electrical circuit troubles are usually due to one, or a combination of two things. First, the direct current path through an individual part may be interrupted in such a way that current can no longer flow through it. Such a part is said to be "open." Since circuits are composed of a varying number of individual parts, it follows that circuits containing open parts are open. One of the jobs of a serviceman is the discovery of which circuit and then which part is open.

Another basic trouble the serviceman is often called upon to locate is known as a "short-circuit." Briefly, a short-circuit is any undesirable connection existing between the two sides of a circuit (positive and negative) or between any two points in a circuit. It is undesirable because it often causes excessive current flow and consequent damage to individual parts. If then damage to other circuit components may result from an accidental short-circuit, opens and short-circuits may exist simultaneously.

To give point to the discussion which follows, all types of ohmmeters will be treated as a device having two test leads and an indicating

meter operating on the series ohmmeter principle. Every possible circuit combination cannot be described. Our discussion will be confined to basic test procedures which will make it possible for the serviceman to test any combination.

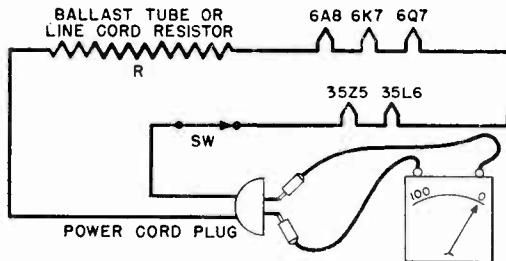

Fig. 5

### Continuity Tests

When a serviceman tests a part or circuit for "continuity," he is determining whether or not the part or circuit has a complete d.c. electrical path. Thus, continuity tests will disclose both open parts and open circuits. Consider the circuit given in Fig. 5.

Here is a typical AC/DC receiver filament circuit. All the parts are connected in series so that the current which flows through one part must flow through all the other parts in turn. Obviously, a break in any one part will prevent the flow of current through all the parts and even good tubes will fail to light up. To check the continuity of such a circuit it is necessary to close the switch to simulate operating conditions and then connect the test leads to the prongs of the power cord. If everything is normal, we will get a meter reading. The meter reads because current from the ohmmeter flows through the circuit we are testing. If resistor R or one of the tube filaments is burned out, current from the ohmmeter will not be able to flow through the circuit and the meter pointer will remain stationary at the left side of the meter.

In the above instance, it isn't even necessary to read the meter. All we are interested in is establishing continuity. Thus, when we get a meter reading we know that current can flow.

Of course, filament circuits are not the only ones which may be tested for continuity. *Any* circuit or part through which direct current flows can be tested for continuity by observing a few simple precautions. The most important precaution to observe when using an ohmmeter is to disconnect the circuit under test from any source of voltage. Figure 5 can be used to illustrate what is meant.

Suppose that the power cord were inserted in a wall outlet providing 110 volt a.c. or d.c. power. If we could conveniently connect to the prongs of the power cord plug when it was in the wall socket we would be connecting our ohmmeter directly across the power line. The high voltage would ruin it. Therefore, Rule No. 1 for using an ohmmeter is:

**Always Completely Disconnect The Receiver Or Circuit Being Tested From The Source of Voltage.**

*Closed Circuits Must Be Opened Up*

Figure 6A illustrates a closed circuit composed of inductance and resistance that might be used in some more extensive circuit. It is desired to test the closed circuit to see if current can flow through it.

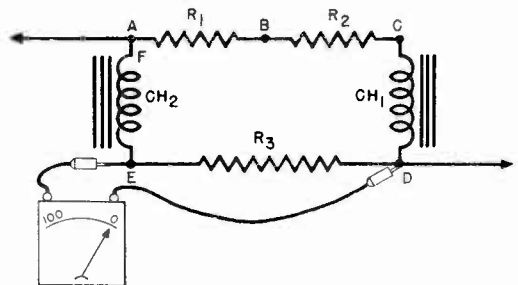

Fig. 6A

Application of the test leads to any individual part (such as points D and E) will give a false indication for current from the ohmmeter has *two* paths it can take. One path of course is directly from one ohmmeter lead to the other through resistor R<sub>3</sub>. The other path however, is through Ch 1, resistors R<sub>1</sub> and R<sub>2</sub>, and Ch 2.

If R<sub>3</sub> were open you would not suspect it by connecting the leads as described above for the current from the ohmmeter would then take the parallel path around R<sub>3</sub> and it would seem as though continuity were established through R<sub>3</sub>. Again, were either choke coil or resistors R<sub>1</sub> and R<sub>2</sub> open, the current from the ohmmeter would flow through R<sub>3</sub> thus falsely indicating circuit continuity through the other resistors and the choke coils.

In order to get a true indication, therefore, it is obvious that the closed circuit must be opened up so that the ohmmeter can become a part of the circuit. This is illustrated in Fig. 6B. Now, if the circuit has continuity, current will flow and the meter will read. Should any part be open, no current will flow. Our second precaution may now be stated:

**A Series-Type Ohmmeter Must Be Connected In Series**

With The Circuit Under Test So Current From The Ohmmeter Can Flow Through Each Part Successively If Continuity Exists.

It is important that the serviceman recognize the existence of parallel current paths and make his tests accordingly. Another case is illustrated in Fig. 7A.

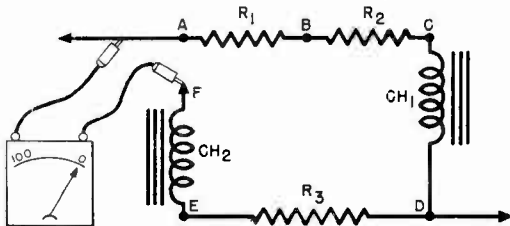

Fig. 6B

Here we have a simple a.f. stage fed by a transformer across which a potentiometer is connected to act as a volume control. The problem is to check the volume control for continuity.

If the ohmmeter is connected as shown at A, the meter will indicate continuity whether the volume control is good or bad because of the parallel current path through the transformer to the chassis. The volume control must be isolated from the transformer winding. This may be done by disconnecting one end of the volume control from the transformer as has been done in Fig. 7B.

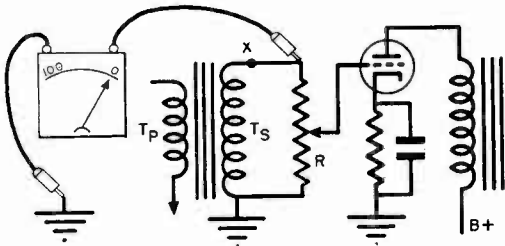

Fig. 7A

Now, either the volume control or the transformer winding can be checked. To check the volume control simply connect the meter between ground (chassis) and the end which has been disconnected from the transformer. If it is desired to check the transformer too, just move the test lead from the unsoldered end of the volume control to the ungrounded end of the transformer winding.

#### Determining Which Part is Open.

It isn't enough that the serviceman know a particular circuit is open; he must find the defec-

tive part (or connection) and either repair or replace it. In order to do this he must make point-to-point tests eliminating one part at a time. Refer to Fig. 6B and we will show how this may be done. Let us suppose that choke 1 is open.

When the test leads are connected to points A and F so that all the parts are included in the test circuit, the meter pointer fails to move thus indicating an open somewhere in the circuit. The first test will probably be a visual one in which the serviceman will look carefully for incompletely soldered joints. Usually he will pull on the various leads with a pair of pliers to see if there are any loose connections. If he finds one or more loose connections he resolders them and tests the entire circuit again to see if the trouble has cleared up. If the ohmmeter still indicates the circuit to be open, he proceeds to test each part in the circuit.

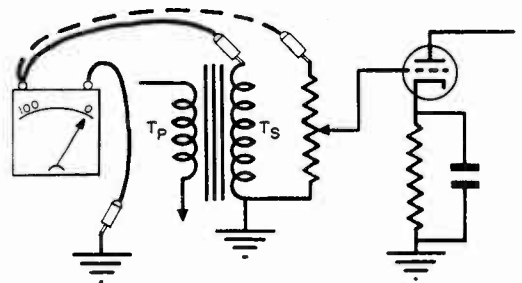

Fig. 7B

Using terminal F as the reference point, connect one test lead to this terminal and leave it there. Now, connect the other test lead to point B thus eliminating  $R_1$  from the test circuit. If the ohmmeter gives a reading with the test lead connected to B and no reading when the test lead is connected to A,  $R_1$  is open. Let us go on, however, for we have assumed choke 1 to be open.

Move the test lead from point B to point C. Again no reading is obtained and we conclude that  $R_2$  is not the offending part. When we connect the test lead to point D however, the story is different. Now we get a meter reading for current from the ohmmeter flows through choke 2 and  $R_3$  if they are O.K.

We didn't have to connect our free test lead to point B for the first check. We could just as well have held it on point E. This time, however, the meter would have given a reading because choke 2 (the only part now in the test circuit) is good. If we moved the test lead from point E to point D we would still get a reading for  $R_3$  is O.K. too.

However, when we make connections at point *C* we get no reading for we have assumed choke 1 is open. This time our test results are just the opposite from what they were when we began the test at point *B*. This leads us to the conclusion that when the result of our first test is the same as the result for the complete circuit test we will not have found the defective part until we get a meter reading. On the other hand, if our first test result shows continuity we will get indications of continuity until we have passed the defective part.

Any circuit can be tested by the point-to-point method just described. To apply the method it is only necessary to proceed from one part in the circuit to the next in order. Don't skip any parts or your results will be misleading.

Of course, it would have been possible to check each individual part in the circuit of Fig. 6B by connecting the test leads directly across each of them in turn. Many servicemen prefer to do it this way. The results are just as conclusive. When you fail to get a reading, the test leads are connected across the offending part.

#### What About Short-Circuits?

We have already defined a short-circuit as an undesirable connection existing between two sides (positive and negative) of a circuit or between two points in a circuit. These two basic ideas are illustrated in Fig. 8.

Resistor  $R_1$  is "short-circuited" because its terminals *C* and *D* are at the same electrical potential as the result of the direct wire connection (considered zero resistance) between them. Whatever current flows in the entire circuit will take the zero resistance path around  $R_1$ .

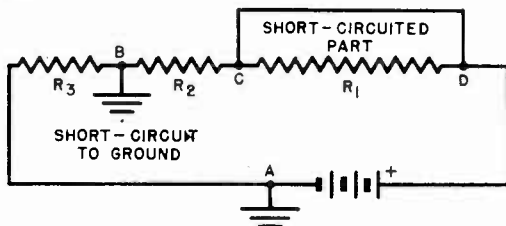

Fig. 8

Points *A* and *B* are at the same potential too for they are both connected to ground. *A* is connected to ground intentionally. Point *B* is connected to ground accidentally. Again the circuit current will take the zero resistance path through the ground connection, thus making the current bypass resistor  $R_3$ . The fact that these undesirable connections make possible an elec-

trically shorter path (lower circuit resistance) originated the term "short" circuit.

#### Locating Short-Circuited Parts

Individual parts as well as complete circuits may become short-circuited. Since every part has a definite amount of resistance when it is in normal operating condition, it stands to rea-

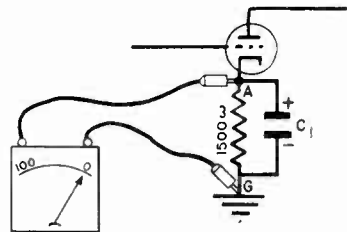

Fig. 9

son that short-circuits will materially lower that resistance. In most instances, a short-circuit will reduce the resistance to zero. Thus, if a serviceman in checking the continuity of circuits simultaneously measures the circuit resistance and compares the value indicated by his ohmmeter with the value he knows the circuit should have he can tell immediately whether or not any part in that circuit is likely to be short-circuited. Let's work out a practical example.

A typical example is the case of a shorted bypass condenser connected across the cathode resistor in an audio amplifier stage. Consider Fig. 9 and suppose the condenser is completely shorted. The consequences of such a condition are readily recognized as a lack of bias.

With condenser  $C_1$  shorted, the meter pointer will move all the way over to the right of the scale and indicate zero resistance when we connect our ohmmeter leads to points *A* and *G*. Unless there is visible evidence that the condenser is defective, however, we have no right to assume that the condenser is defective rather than the resistor being grounded at point *A*. It is evident therefore that we have to disconnect the condenser from cathode terminal *A* and check it separately by measuring the resistance between the unsoldered condenser lead and chassis ground point *G*. If we get the same low resistance reading while checking the condenser alone we know the condenser is defective for by itself it should offer a very high resistance to the flow of direct current if it is good.

Should the condenser test near the desired high resistance, we must check at points *A* and *G* again to determine if the bias resistor is grounded at point *A*. We now have the prob-

tem of deciding whether it is the resistor that grounds at or near point A or if it is a defective tube or tube socket that causes the ground at point A. We shall answer this question shortly. Right now we want to give a practical example of a ground which shorts out one or more parts. The location of such a ground will lead right into the question we have raised here concerning the resistor, tube, tube socket and cathode terminal A.

### Isolating a Defective Condenser

It is common practice in modern receivers to place a screen-grid bypass condenser from each screen-grid tube socket terminal to ground (or cathode). Thus, in a receiver having let us say three screen-grid type r.f. amplifier tubes, there may be three bypass condensers as shown in Fig. 10. If the screen voltage is taken from a tap on the voltage divider there may be a fairly high capacity bypass condenser from that tap to the ground or B— point of the voltage distribution system. ( $C_4$  in Fig. 10).

The various screen-grid terminals of the tube sockets are interconnected so there will be the same amount of voltage on all the screen-grid elements.

Let us assume that the complaint is a lack of screen-grid voltage on all three tubes. Analyzing the problem we find that this could be caused by a breakdown of anyone of the four bypass condensers illustrated or due to an open in the voltage divider system between the tap and the high B+ (B++) end. In order to avoid other problems entering the picture, let us assume that you have already established continuity between B++ and the screen-grid terminal of tube 1. The trouble therefore must be a defective bypass condenser but the question is, which one?

Each condenser presents a potential path for direct current from B+ to ground. The only way we can find the offending part is to disconnect one condenser at a time and check the circuit. Here is how to go about it.

First, substantiate your analysis that there is a shorted condenser by measuring the resistance between ground and any one of the screen-grid terminals. Here you will see the necessity of recognizing parallel current paths for unless the screen-grid circuits are disconnected from the voltage divider tap, the resistance of the voltage divider from the B+ to ground will always be in your test circuit and you cannot detect a condenser which is only partially shorted (leaky). So, having disconnected the screen-grid circuits from the B+ voltage divider tap, you measure the resistance between the screen-grid terminal of tube 1 and the chassis and get a full scale reading when you should get no reading at all.

Disconnect condenser  $C_1$  from the screen terminal of socket #1 and again measure between the screen terminal and ground. If the ohmmeter now shows an open circuit,  $C_1$  is shorted. To prove it, measure the d.c. resistance of  $C_1$ .

Suppose, however, that with  $C_1$  disconnected the resistance was still low. What then? The obvious inference is that you have not as yet found the defective condenser so disconnect  $C_2$  from its tube socket terminal and check the circuit again. If the resistance comes up to where it ought to be,  $C_2$  is the defective bypass condenser. If the resistance is still low, proceed to the next potential source of trouble. In this case it will be condenser  $C_3$ . Follow this procedure until you have found the defective part.

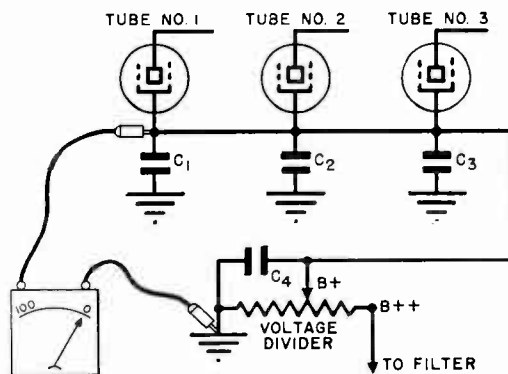

Fig. 10

In our example of the shorted bypass condenser in parallel with the cathode bias resistor (Fig. 9) we mentioned that if the resistance between A and G were low with  $C_1$  completely disconnected we had no right to assume that the resistor was at fault for the tube or tube socket might be grounded. As in the case of the screen bypass condensers, we'll have to eliminate the various possibilities one by one.

Disconnect the resistor from point A. If the resistance from A to G with the resistor disconnected gives the normal open circuit indication, the resistor must have been grounded.

The point to be gained from the two examples above is that once the defective stage or circuit has been found, each possibility that would cause the observed test result must be investigated. You must keep right at the circuit, part by part, point by point until you have found the trouble.

### Testing Individual Parts

The above testing procedures will mean nothing to you unless you have some idea of what re-

sistance to expect when testing various parts. For instance, unless you knew that there must be no connection between the screen-grid elements and ground with the circuit disconnected from B+ you could not have interpreted your ohmmeter reading. You must know the approximate amount of resistance to expect for various tests. Circuit diagrams which have resistance values for the various parts marked on them aren't always available. In fact, you may sometimes have to check parts and circuits without the aid of a diagram.

### *Checking Resistors*

A resistor is a device designed to offer opposition to the flow of electric current. The values used in modern receivers range from a few ohms to several million ohms. To adequately cover this wide range, most commercial ohmmeters provide several ranges each measuring with acceptable accuracy a definite portion of the total resistance range encountered in service work. In addition to being able to analyze the circuit and apply the ohmmeter in such a way as to locate the defective part, the serviceman must also choose the proper range of the ohmmeter to get the desired results.

Now you will either know the approximate resistance you should get or you will not know it. That much is obvious. In some instances the value is printed right on the resistors. In other cases a group of colors will be used to designate the value of the part. In still other instances, however, a resistor can be so badly burned that all means of identifying its value from printed or color coded values is impossible.

When you know the resistance value it is easy to set the ohmmeter selector switch to the proper range position, connect the test leads to the part and read the meter scale. In all instances except where the range being used is read directly from the meter scale, you'll have to multiply your meter reading by the multiplying factor indicated by the range position pointer.

As an example, suppose your ohmmeter scale is calibrated to read from zero to 100 and the selector switch is set at 100xR. This means that you must multiply all values indicated by the meter pointer by 100 in order to get the actual resistance value. Thus, a meter reading of 62 would indicate a resistance of 6200 ohms.

### *Unknown Resistance Values*

When you don't know the resistance value a different procedure must be used. In this instance you set the ohmmeter range selector to the *highest* possible range of the test instrument. Observation of the position of the meter pointer will tell you if you can lower the range

and thus get a more accurate reading.

Try to select the range which will give a meter pointer deflection of approximately mid-scale. Here you know your meter is reasonably accurate and it is easy to read the scale and apply the correct multiplying factor.

There is a definite reason why you should start with the higher range. Suppose you were checking the circuit for continuity as well as for proper resistance. If you have no idea as to what resistance values you will encounter you must be prepared to show continuity through the highest possible resistance your meter will measure. Should you get no reading on the highest range you have immediately determined that the circuit or part is open or that its resistance is so high that even the highest range of your meter won't measure it. If you use an ohmmeter with a high range of 10 to 20 megohms you can be reasonably assured that failure to get a reading on this range means an open circuit or part.

### *Checking Coils*

There is no difference between the procedure used to check coils and the procedure used to check resistors. Simply connect the ohmmeter test leads to the terminals or leads of the coil and read the meter. The ohmmeter range used for coils will be governed by the expected resistance value and in most instances it will be one of the lower ranges. Perhaps it will even be the very lowest range of the ohmmeter.

Occasionally it is necessary to determine whether or not a coil has shorted turns. The average ohmmeter will not detect the difference in resistance caused by one or even several turns of wire being shorted together. In the case of very low resistance coils it is often possible to use a shunt-type ohmmeter. The difference in resistance which one shorted turn of wire will make must be known, however. Don't rely too much on the test results, however, for the part you are checking may not have the exact amount of resistance it is rated to have.

### *Checking Condensers*

In checking condensers the thing to remember is that a good condenser will not allow direct current to flow through it. If it permits the flow of direct current its days as a condenser are at an end. With a few qualifications we can base our condenser tests on the above facts.

The first qualification of course will be a differentiation between condensers having paper or mica insulation and condensers of the electrolytic type commonly used in the filter systems of vacuum tube power supplies. This differentiation is necessary for whereas the paper and mica insulated condensers permit no direct

current to pass through them, (at least up to the break-down voltage) the electrolytic types do permit current to pass through them.

Regardless of the type of condenser being tested, the newcomer to radio should have a clear picture in mind as to what happens when the test probes of an ohmmeter are connected to a condenser.

An uncharged condenser acts like a resistor of very low value for the first few moments voltage is applied to it. An immediate rush of electrons takes place from the voltage source onto one set of plates of the condenser. Thus, when connecting the leads of a series-type ohmmeter to a good condenser, the meter pointer immediately moves to the right indicating current flow.

As the voltage of the condenser increases, the charging current decreases. This makes the meter pointer of the ohmmeter move back toward its normal zero-current position at the left of the scale. When the condenser is completely charged, the charging current is zero and the ohmmeter indicates an open circuit.

When we apply the leads of an ohmmeter to any type condenser, the above action takes place to a degree determined by the capacity of the condenser provided the condenser is normal. If the condenser is not normal the action will be different.

The point to grasp here is the fact that a good condenser will make the ohmmeter pointer move sharply to the right and then fall back towards the left of the scale, whereas an open condenser will fail to give any meter pointer movement at all (for current does not flow in this case) and a shorted condenser will give a continuous meter reading. Let us now go back to our differentiation between the various types of condensers.

Considerably more current will flow through an electrolytic condenser with one polarity of applied voltage than will flow with the opposite polarity of applied voltage. Thus it is important that electrolytic condensers be connected into circuits with proper polarity. And for the same reason, the correct polarity of ohmmeter test leads must be observed when checking electrolytics.

When checking electrolytics connect the test leads to the condenser and hold them in contact long enough for the meter pointer to assume a reasonably steady reading. Note the meter reading and remove the test leads. Now short-circuit the condenser terminals to discharge it.

Unless you discharge the condenser before you test it again the charge on the condenser will act

in series with the battery of the ohmmeter and cause a meter current many times the normal full-scale value. Thus the meter may be damaged unless the condenser is discharged before testing it. This is also true of paper condensers of large capacity.

Now connect the test leads to the condenser again but this time with the opposite polarity. Thus, if your first test was made with the red test lead to the positive condenser terminal, connect the black test lead to the positive terminal this time. Again hold the leads on the condenser terminals long enough to get a steady meter reading. Compare the two meter readings. The reading giving the *highest* resistance is the one which indicates the worth of the condenser. The lower resistance reading merely indicates that for this reading the polarity of the ohmmeter leads was incorrect.

Since electrolytics pass current regardless of the applied voltage polarity, the big question is, how much leakage can be tolerated in a good condenser? Unfortunately, authorities differ as to the amount. Obviously the capacity of the condenser, its age, whether or not it has been operated at higher than normal temperature and voltage as well as the amount of voltage applied to it by the ohmmeter are controlling factors. All these variables make it practically impossible to set up definite limits which will cover every case.

If you must have a limit, consider seriously the replacement of condensers which check less than 100,000 ohms for the *highest* of your two test measurements. You can always temporarily substitute a good condenser and prove whether or not a replacement is advisable. Don't hesitate to substitute a good condenser if there is any doubt in your mind as to test results. This is a case where the operation of the set should be the "proof of the pudding."

#### *Tolerance*

An article of this kind would not be complete without a section devoted to tolerance. Tolerance as you will soon see, plays a mighty big part in successfully interpreting your test results.

Tolerance is the permissible variation from a rated or assigned value. It is usually expressed as a percentage. Thus, a resistor rated 10% accurate may measure any value from 5% *below* its rated value to 5% *above* its rated value. If a resistor was specified to have a resistance of 100,000 ohms and a tolerance of 10%, it could measure any value between 95,000 and 105,000 ohms and still be considered as a 100,000-ohm resistor in spite of the 10,000 ohm variation.

Parts may vary more in one direction than another. By that we mean that a condenser for

instance, might have a tolerance of 10% below the rated value and a tolerance of 30% above the rated value. Some parts may be rated simply a certain percentage "plus or minus" ( $\pm$ ). This means that the variation is the same amount above and below the rated value.

Inasmuch as variations from the standard values will exist even when parts work okay, this fact must be taken into consideration in using an ohmmeter. If a resistor rated 1000 ohms with a tolerance of 10% measures 900 ohms, it must be considered okay. If the ohmmeter has the average 10% error, the resistor could measure as low as 800 ohms and still be okay. When you use an ohmmeter therefore, be sure to allow for variations from the standard rated values and also allow for errors in your ohmmeter.

Summarizing this discussion we have the following points of importance:

1—There are many ways of measuring resistance but from a serviceman's standpoint the ohmmeter method is the most practical.

2—The series-type ohmmeter circuit is best adapted to the measurement of high resistance values while the shunt-type circuit is best adapted to the measurement of low resistance values.

3—Ohmmeters must never be used when power is applied to the apparatus under test so that it is in operation. This is to avoid damage to the ohmmeter.

4—You have to watch for parallel current paths when checking individual parts as well as complete circuits so that your test results will not be misleading.

5—Resistances, coils and condensers of the paper or mica insulated types may be checked with an ohmmeter and satisfactory results obtained but not so with electrolytic condensers.

6—You must allow for the normal manufacturing tolerance of the parts you are measuring and you must also allow for errors in your ohmmeter.

If you will keep the above facts in mind you will find it extremely easy to use an ohmmeter and make its indications mean something. An ohmmeter is one of the most valuable service instruments you can own. When you have learned how to use and care for it, you'll be dollars and cents ahead.

Ten years from now you will wish you had bought more U. S. War Savings Bonds. Buy all you can—for your sake—for the boys on the firing line—for The United States of America. Back the attack! Buy Bonds! Buy Now! Buy today!

## Go Ahead and Shoot!

I remember that horrible night in the trenches as if it were but yesterday. There we stood, horrified. The kid knelt, his right hand raised, his face ashen white. Shells burst overhead, casting eerie shadows upon the faces of the panic stricken men. It could not happen!

"For goodness sake, shoot, go ahead and shoot," cried one of the men.

"Give him time, men! Take it easy," soothed the sergeant.

The kid drew back his arm slowly. The eyes of eight men were riveted upon his hand. Suddenly his arm shot forward. His fingers opened, and by the light of the flares in the skies, we saw the most ghastly impossibility happen! There it lay before our eyes, another seven. The lucky stiff had made eight passes in a row.—Reprinted from Asheville Amateur Radio Club Bulletin.

— n r i —

## Opportunity for Experienced Sound and Projection Men

Men who are draft exempt or over the draft age, men who have had several years experience installing and servicing 35-mm. sound and projection equipment, and are free to travel anywhere within the continental limits of the United States are invited to write Mr. G. L. Bub, Manager, U. S. Army Motion Picture Service, 3327-A Locust St., St. Louis, Mo.

Positions are open as Electronic Engineers at a starting basic salary of \$3200.00 a year, to men who can qualify.

— n r i —



Say, Boss, I got my draft board notice today!!





# N.R.I. ALUMNI NEWS

F. Earl Oliver .....	President
Peter J. Dunn .....	Vice-Pres.
Louis J. Kunert .....	Vice-Pres.
Earl R. Bennett .....	Vice-Pres.
Chas. J. Fehn .....	Vice-Pres.
Earl Merryman .....	Secretary
Louis L. Menne .....	Executive-Secretary

## Nominations for 1944

Again it is time to call for nominations for officers of the N.R.I. Alumni Association. Our constitution provides that two months prior to January 1 of each ensuing year, nominations for the various offices shall be called for from the membership through the columns of NATIONAL RADIO NEWS.

Our constitution further provides that one month prior to January 1 of each ensuing year the two nominees for each office shall be submitted to the entire membership. The membership shall in return submit the ballots properly marked, voting for one nominee for each office.

In accordance with this procedure it is our custom to call for nominees for the approaching year in the issue of the NEWS corresponding to this one, then present the two nominees for each office in the next issue of the NEWS, for the election of one, to take office on January 1.

All present officers may be candidates to succeed themselves, except the President. In order that the honor of holding office in our organization may come to a greater number of members the term of office for the President is limited to one year.

Mr. F. Earl Oliver, of Detroit, therefore will relinquish the office of President of N.R.I.A.A. on December 31 of this year. He has been a loyal, hard worker for our Alumni Association.

In August, Mr. Oliver came to Washington, where he spent three days with Mr. Smith, Mr. Haas, Mr. Menne and other members of our staff in conferences regarding the affairs of our Alumni Association. The officers of our Alumni Association serve without compensation. Our members therefore will join us at headquarters in expressing our thanks to Mr. Oliver for giving three precious days of his regular vacation to come to Washington in line of duty as President of the N.R.I.A.A.

On December 31 of this year Mr. Oliver's name will go on our Honor Roll along with past presidents John E. Fetzer, K. W. Griffiths, T. J. Telaak, Peter J. Dunn, Earl R. Bennett, Clarence Stokes, Dr. Geo. B. Thompson and Edward Sorg. In the meantime, of course, Mr. Oliver still has several months to serve until his term expires.

All present Vice-Presidents may be renominated to succeed themselves. Eight candidates for Vice-President will be nominated—four to be elected in the final run-off, details of which will be given in the next issue of NATIONAL RADIO NEWS.

Mr. Earl A. Merryman, who is "on leave" while on overseas duty, is a candidate for reelection as Secretary, an office he has held since our Alumni Association was organized in 1929. Mr. Louis L. Menne is a candidate for reelection as Executive Secretary.

Usually our new President is selected from among the Vice-Presidents. If this same custom is to follow this year it is anticipated that Louis J. Kunert, of New York Chapter, and Charles J. Fehn, of Philadelphia-Camden Chapter, will be very strong candidates. For three consecutive years now our President has been a man from the Middle West or Far West. The members in the East say they are going to put their candidate over this year. It could be either Kunert or Fehn.

In order that our members may have a wide list of candidates to choose from we are submitting the names of members located in various parts of the country. These are submitted merely to be of assistance to you. Any member of the Alumni Association may be a candidate for office. Please use ballots on pages 29 and 30.

Allen McCluskey, Birmingham, Ala.  
 Don Smelley, Cottondale, Ala.  
 Julius L. Billy, Mobile, Ala.  
 H. E. Nichols, Lowell, Ariz.

Edgar E. Joiner, El Dorado, Ark.  
 P. Rochelle, Little Rock, Ark.  
 Willis F. Sims, Pine Bluff, Ark.  
 Oliver B. Hill, Burbank, Calif.  
 C. F. West, San Francisco, Calif.  
 R. H. Rood, Los Angeles, Calif.  
 Dr. Geo. B. Thompson, Los Angeles, Calif.  
 P. A. Abelt, Denver, Colo.  
 John Jerry, Denver, Colo.  
 A. H. Wilson, Canon City, Colo.  
 W. R. Haberin, Bridgeport, Conn.  
 M. E. Perkins, Bristol, Conn.  
 Joseph Snyder, Danbury, Conn.  
 Wm. F. Speakman, Wilmington, Del.  
 Lambert P. Ayres, 3rd, Millsboro, Del.  
 J. J. Jenkins, Washington, D. C.  
 Clyde D. Kiebach, Washington, D. C.  
 Robert E. Maney, Washington, D. C.  
 Edward Merchant, Washington, D. C.  
 Jesse O. Starr, Washington, D. C.  
 Glenn G. Garrett, Bonifay, Fla.  
 Austin L. Hatch, Ft. Lauderdale, Fla.  
 Stephen J. Petruff, Miami, Fla.  
 W. P. Collins, Pensacola, Fla.  
 Dan C. Yates, Albany, Ga.  
 R. R. Wallace, Ben Hill, Ga.  
 L. E. McAllister, Mt. Berry, Ga.  
 John C. Bills, Boise, Idaho.  
 Arvil H. King, Montpelier, Idaho.  
 Jerry C. Miller, Chicago, Ill.  
 Earl R. Bennett, Evanston, Ill.  
 James Cada, Berwyn, Ill.  
 Harry Andresen, Chicago, Ill.  
 Harold Bailey, Peoria, Ill.  
 Lowell Long, Geneva, Ind.  
 G. H. Millsbaugh, Anderson, Ind.  
 Chase E. Brown, Indianapolis, Ind.  
 Russell Tomlinson, Marion, Ind.  
 Raymond L. Drake, Cedar Falls, Iowa  
 E. C. Hirschler, Clarinda, Iowa.  
 O. L. Kirkpatrick, Augusta, Kans.  
 Louis A. Harrison, Ellis, Kans.  
 William B. Martin, Kansas City, Kans.  
 K. M. King, Wichita, Kans.  
 Hazelton M. Yober, Topeka, Kans.  
 Wm. S. Nichols, Cynthiaana, Ky.  
 Wallace G. Baptist, Lexington, Ky.  
 S. E. Banta, Gonzales, La.  
 James H. Foster, New Orleans, La.  
 Lawrence Merz, New Orleans, La.  
 Peter J. Dunn, Baltimore, Md.  
 E. W. Gosnell, Baltimore, Md.  
 J. B. Gough, Baltimore, Md.  
 Samuel Robinson, Hagerstown, Md.  
 G. O. Spicer, Hyattsville, Md.  
 Austin Vaehone, Bath, Maine.  
 Joseph Dubois, Biddeford, Maine  
 Ralph E. Locke, Calais, Maine.  
 Laurence E. Grant, Belmont, Mass.  
 Louis Crestin, Boston, Mass.  
 A. Singleton, Chicopee, Mass.  
 Omer Lapointe, Salem, Mass.  
 O. A. Grendahl, Duluth, Minn.  
 Francis P. Hoffman, Minneapolis, Minn.  
 Lloyd R. Olson, Minneapolis, Minn.

J. Stanish, Detroit, Mich.  
 Harry J. Stephens, Detroit, Mich.  
 Frederick Gaul, Freeland, Mich.  
 B. B. Reeves, Walnut Grove, Miss.  
 Ralph Black, Grayridge, Mo.  
 C. S. Burkhart, Kansas City, Mo.  
 A. Campbell, St. Louis, Mo.  
 C. W. Wichmann, Inverness, Mont.  
 Carl M. Darner, Sweet Grass, Mont.  
 U. S. Capes, Fairmont, Nebr.  
 Melvin C. Ashbaugh, Merna, Nebr.  
 C. D. Parker, Lovelock, Nev.  
 I. N. Hartman, Hawthorne, Nev.  
 Arthur Cornellier, Dover, N. H.  
 Clarence N. George, Dover, N. H.  
 E. Everett Darby, Woodsville, N. H.  
 J. A. Stegmaier, Arlington, N. J.  
 John Stein, Union City, N. J.  
 Delbert Delanoy, Weehawken, N. J.  
 Claude W. Longstreet, Westfield, N. J.  
 Gus W. Fisher, Alamogordo, N. Mex.  
 James E. Graham, Carlsbad, N. Mex.  
 Emil Hauzer, Carlsbad, N. Mex.  
 John E. Kreitner, Buffalo, N. Y.  
 Alfred R. Guiles, Corinth, N. Y.  
 L. J. Kunert, Middle Village, L. I., N. Y.  
 Charles W. Dussing, Syracuse, N. Y.  
 Irvin Gardner, Saratoga, N. C.  
 S. J. Pearce, South Mills, N. C.  
 Arvid Bye, Spring Brook, N. Dak.  
 Jacob J. Knaak, Cleveland, Ohio.  
 Richard G. Johnson, Cleveland Heights, Ohio.  
 P. E. Traylor, Maysville, Okla.  
 R. E. Fullhart, Bartlesville, Okla.  
 Emil Domas, Dale, Oreg.  
 George H. Newton, Eugene, Oreg.  
 Elmer E. Hartzell, Allentown, Pa.  
 Charles J. Fehn, Philadelphia, Penna.  
 William Dyson, Pawtucket, R. I.  
 James F. Barton, Greer, S. C.  
 Joel J. Lawson, Aberdeen, S. Dak.  
 Chester Warren, Lead, S. Dak.  
 W. P. Brownlow, Johnson City, Tenn.  
 J. E. Collins, Paris, Tenn.  
 H. A. Gilmore, Amarillo, Texas  
 B. A. McLendon, Dallas, Texas  
 L. H. Watkins, Ogden, Utah  
 Walter Leland, Orleans, Vt.  
 J. W. Gladden, Alexandria, Va.  
 A. P. Caldwell, Buchanan, Va.  
 T. E. Ellis, Richmond, Va.  
 R. F. Keil, Seattle, Wash.  
 R. E. Sawyer, Vancouver, Wash.  
 R. A. Heise, Wheeling, W. Va.  
 Wm. Wiesmann, Fort Atkinson, Wisc.  
 J. C. Duncan, Duncan, Wyo.  
 Romert Kirkman, Calgary, Alta., Canada  
 M. Martin, New Westminster, B. C., Canada  
 E. D. W. Smith, Winnipeg, Man., Canada  
 John T. Dixon, St. John, N. B., Canada  
 Russell Burlhoe, Woodstock, N. B., Canada  
 Donald Swan, Springhill, N. S., Canada  
 G. C. Gunning, Smiths Falls, Ont., Canada  
 E. Bergeron, Sherbrooke, P. Q., Canada  
 J. W. Meadwell, Saskatoon, Sask., Canada

## New York Chapter

None of the various organizations I have joined in the past have given me such a desire to devote my time and energy to than the N. Y. Chapter of N.R.I.A.A. All the fellows I've met there are all clean cut, attentive, cooperative and have a keen sense to learn and increase their knowledge in radio and service work.

Many of the men present have taken up radio as a hobby and their daily work is in diversified fields far from Radio but the desire is 100% to learn more about this wonderful field of Electronics. It is fascinating!

A great deal of time is devoted to service problems. Invariably one to three radio sets are brought to the chapter by the members where the "stickler problems" are ironed out. We all have an opportunity to offer our opinions and make tests to state what and where the trouble lies, using N.R.I. principles and if we still haven't located the hidden trouble, Bert Godas in charge of our Service Forum teaches us "how to do it right." Our sessions are so interesting, time flits by so fast, we hate to break up our meetings but we do have to work the next day and we need rest.

Incidentally Mr. Bert Godas is opening a new store on Buffalo Ave., Brooklyn, N. Y., where he will take care of Radio repair and service work. We all wish him good luck in his new enterprise.

Louis Leung and William Wilson, members, showed up at our last meeting after having been absent for a long spell. We were all glad to welcome them back and hope they will be with us regularly.

We also welcome William Henn a new member who joined us at the last meeting.

Since graduating last June, James Marshall is doing well with his Radio Service work. He never misses any of our meetings. A small room in his house was converted to do the repair work, but as he stated, he didn't expect to be "snowed under" with all the sets coming in, so he is building a fine workshop in his garage. Mr. Marshall retired from active business some time ago and took up an N.R.I. Radio Course as a hobby, but since so much work is coming in because of his "good and honest" work he decided to go back into business. He is well liked by us all and we wish him success.

Lou Kunert, our Secretary, always writes in such kind things about our various members, but he really deserves "the best write up" because through his outstanding efforts he keeps us all together. We hope to see Lou Kunert elected President of our Alumni Association before long

and he will get our full support this year. We all think a great deal of him.

And now you, Mr. Menue, have honored me with your kind letter. I really don't deserve so much credit and praise you and Mr. Kunert have given me. After all, I am only trying to help a worthy cause along. And because all you folks in Washington have built up such a fine Institution to make better Americans and business men of us all through your constant efforts, we feel inspired to learn more and do better.

We all shall be glad to have you and Mr. Smith visit our Chapter again. However we agree with Mr. Smith to wait until the weather gets cooler so we can have a real turnout welcome for you both.

We meet at St. Marks Manor Community Center, 12 St. Mark's Place (between Second and Third Avenues) New York City, every first and third Thursday of the month. All N.R.I. men in the New York metropolitan area are cordially invited to attend our meetings.

BERT WAPPLER, *Chairman.*

— n r i —

## Detroit Chapter

Our meetings were resumed in September and will continue throughout the Fall and Winter on the Second and Fourth Friday of each month. Our regular meeting place is still at the shop of Chairman John Stanish, 2500 Jos. Campau.

Not all of our meetings, however, will be held at our regular meeting place. The plan of meeting at the home or shop of some of our members proved so popular last Spring we decided to continue it. Therefore if you are not on the mailing list, or if there has been any change in your address please communicate with Secretary F. Earl Oliver, 3999 Bedford, Phone Tuxedo 27907 or write to the undersigned at 5910 Grayton.

HARRY STEPHENS, *Assistant Secretary.*

— n r i —

## Phila-Camden Chapter

Ever faithful Vice President Charley Fehn writes us that Phila-Camden Chapter has planned big things for this fall and winter. Details were to come from the Secretary but, as we went to press, the report had not reached us.

Let it be sufficient to say, for this issue, that the Chapter meets on the first Thursday of each month at the Radio shop of Harvey Morris, 6216 Charles St., Philadelphia. If you live in the Philadelphia area and want to get in on something good for Radio men drop in at the next meeting you will be cordially received.

## Here And There Among Alumni Members



Harold P. Towner of Wayland, New York has been passing out cigars. It's a fine baby boy. Towner is spending every possible minute getting acquainted with his son because if papa

passes the final physical he will be one of Uncle Sam's boys, come late October.

— n r i —

Bert Wappler, Chairman of New York Chapter was recently made an Associate Member, Institute of Radio Engineers. Bert is looking for a man with Short Wave Diathermy Equipment experience for his business which is located at 27 W. 24th St., New York City.

— n r i —

Stanley Tulk is now Broadcast Operator at Radio Station CBL, Toronto, Ont., Canada, a branch of the Canadian Broadcasting Corporation.

— n r i —

Julius Hillenbrand of Ridgewood, L. I., N. Y., is quite a Television expert. Has made a real study of Television and will be ready for a post-war boom in this branch of Radio with all it promises when it really breaks out of the laboratories.

— n r i —

Comes a letter from Sgt. Paul Sabin Marks, who is in charge of a CW station with the Army Airways Communication System in Texas. Sgt. Marks graduated in June, 1920. His station chief is Master Sergeant Boyce D. Simmons. Roman P. Stoelb is one of their operators. All three are N.R.I. men.

— n r i —

Joseph E. Tucker of Lancaster, Ohio is averaging \$40.00 a month from his spare time Radio business. Nice bit of money to go into War Saving Bonds.

— n r i —

At the picnic of Chicago Chapter we were glad to see past Chairman August Ketelhut, past Chairman James Cada and his wife, Elsie, past Chairman Clarence Schultz and his wife, Rose; past Secretary Sam Jurieck and his wife, past Secretary Charles Cada and his wife, and past National Vice President Cecil Morehead and his wife, Letha. The spirit of Chicago Chapter runs deep.

— n r i —

Sgt. Orris E. Stark of Osceola, Iowa is taking a course in Radar, somewhere in England. He wrote Chief Dowie, who also spent some time in England, for instructions on how to get around in London via the Underground system. Dowie replied that his main difficulty was carrying a pocketful of those big English pennies.

— n r i —

Julius C. Vessells, Chief Engineer, WDOD, Chattanooga, Tenn., sent some pictures of their new

studios and equipment. Have one of the finest stations in the country. The transmitter is a Federal 165-A 5KW. Mr. Vessells is earning about \$4,500.00 a year—and we mean earning because he has been putting in plenty of overtime having lost six men in the engineering department to the Armed Services.

— n r i —

Pete Dunn is on secret duty with the Navy. Doing a grand job. Pete is a veteran of the last war and knows how to dish it out.

— n r i —

Edgar Van Gilder of Denver, Colorado has lost the sight of his right eye because of Glaucoma, hardening of the eye-ball. The doctors tell him that eventually the other eye will likewise be affected. Not a pleasant prospect for our loyal and good friend Van. He sends the following poem, by Lynn Tefft, which Van says fits J. E. Smith perfectly. "I like a towering, bronzy, robust man, Whose eyes have swept both wave and smoky sage. And gained their crinkles buffeting years and men. Seasoned in kindness, mature in wisdom."

— n r i —

Clive W. Keemer of Dayton, Ohio has been recommended for promotion to Chief Supervisor of Radar at an increase in salary. Has made rapid strides in the Signal Corps—from \$1,800.00 per year in Feb. 1942 to \$2,900.00 in July, 1943.

— n r i —

L. D. Lewis is Flight Radio Operator for Braniff Airways, Inc., Brownsville, Texas. May be a Radio instructor in an Army school before long.

— n r i —

Peter Modlowski of Fall River, Mass., is Senior Radio Mechanic with the Signal Section of the Air Corps. Travels from place to place in his fully equipped army truck.

— n r i —

Albert C. Christensen of Sidney, Nebr., has upped his earning to \$70.00 a week. He has a nice full time Radio business which he started on part time and steadily built up. Good Radio man, that Christensen.

— n r i —

James L. Brandon of Gastonia, N. C., is a Lieutenant in the Air Corps, serving as Radio Navigator.

— n r i —

Louise Schultz, daughter of Mr. and Mrs. Clarence Schultz of Chicago, is taking a Government sponsored Course in Radio Engineering at Purdue University. Quite an honor!

— n r i —

Alfred J. Beauchamp, who had a fine Radio servicing business in Owatonna, Minn., failed to recover from a major operation and passed away at a hospital in Rochester, Minn. Our deepest sympathies are extended to Mrs. Beauchamp.

## Baltimore Chapter

Our chapter was honored by Mr. Earl Oliver, President of the N.R.I. Alumni Association, who visited us last month, accompanied by Mr. Menne, Executive Secretary.

Mr. Oliver explained some of the things which Detroit Chapter is and has been doing. He described the zone system which, briefly, means dividing the city into zones. When a member gets a service call outside of his zone he refers it to the member who lives in that zone. Thus by helping one another the members are better able to concentrate their services in territory near the homes or businesses of each, a matter of great importance in these days of restricted travel.

Another topic of interest was Mr. Oliver's explanation of the plan of meeting at the homes of members occasionally. The member is advised in advance that he is to make a talk on a picked Radio subject. He is given ample opportunity to prepare himself. If he gets into "deep water" he is assisted by some of the more experienced members.

Our meetings have continued right through the summer with a good group of stand-bys in regular attendance. Now that the cooler evenings are here we look for a steadily increasing attendance.

With Chairman Gosnell at the helm our members are sure to get something worthwhile for their trouble in attending. Vice Chairman Rathbun leads us in doing actual Radio servicing. An N.R.I. member living in this area dropped in for the first time bringing with him a radio which had him stumped. In a very short time the trouble was located and the repairs were made right there and then. This member was amazed to learn that the dues are only 25c a month to help pay the rent for our meeting place and joined at once. He has been a regular ever since.

Meetings are held on the second and fourth Tuesday of each month at 8:00 P.M. at Redman's Hall, 745 W. Baltimore St., in Baltimore.

P. E. MARSH, *Secretary.*

— n r i —

## Directory of Officers

[To Serve Until January, 1944]

President—F. Earl Oliver, Detroit, Mich.

Vice Presidents—

L. J. Kunert, Middle Village, L. I., N. Y.

Chas. J. Fehn, Philadelphia, Penna.

Peter J. Dunn, Baltimore, Md.

Earl R. Bennett, Evanston, Ill.

Secretary—Earl Merryman, Washington, D. C.

Executive Secretary — L. L. Menne, National Headquarters, Washington, D. C.

## Nomination Ballot

All Alumni Association Members are requested to fill in this Ballot and return it promptly to National Headquarters. This is your opportunity to select the men who you want to run your Association. Turn this page over—the other side is arranged for your selections.

After the ballots are returned to National Headquarters they will be checked carefully and *the two men having the highest number of votes* for each office will be nominated as candidates for the 1944 election. The election will be conducted in the next issue of NATIONAL RADIO NEWS.

The President cannot be a candidate to succeed himself but you may nominate him for any other office, if you wish. You may, however, nominate all other officers who are now serving, for President or any office, or select entirely new ones. It's up to you—select any men you wish as long as they are MEMBERS IN GOOD STANDING OF THE N. R. I. ALUMNI ASSOCIATION. Be sure to give the city and state of your selections to prevent any misunderstanding. A list of the 1943 officers is given in the opposite column.

Detach this slip carefully from your NATIONAL RADIO NEWS so as not to damage the book. Tear off the slip at the dotted line, fill it out carefully, and return it immediately to L. L. Menne, Executive Secretary, N. R. I. Alumni Association, 16th and U Sts., N. W., Washington, D. C.

Your signature .....

City ..... State.....

(Over)

*The 1944 nomination is a very important one. Choose carefully the men you desire to handle the reins of the Alumni Association for the coming year. Let's all do our part to help the staff handling the elections, by submitting ballots on or before October 15, 1943.*

Tear carefully along this line

## Nomination Ballot

L. L. MENNE, *Executive Secretary*,  
 N. R. I. Alumni Association,  
 16th and You Sts., N. W.  
 Washington, D. C.

I am submitting this Nomination Ballot for my choice of candidates for the coming election. The men below are those whom I would like to see elected as officers for the year 1944.

### MY CHOICE FOR PRESIDENT IS

.....  
 City..... State.....

### MY CHOICE FOR FOUR VICE-PRESIDENTS IS

1. ....

City..... State.....

2. ....

City..... State.....

3. ....

City..... State.....

4. ....

City..... State.....

### MY CHOICE FOR SECRETARY IS

.....

City..... State.....

### MY CHOICE FOR EXECUTIVE SECRETARY IS

.....

City..... State.....

## Chicago Chapter



Although meetings were suspended during July and August we did get together at our annual picnic. It was a grand outing, on a clear if somewhat warm day.



Chairman Andresen, assisted by Walter Wilkes and Leonard Senglin made arrangements for the picnic at beautiful Caldwell Woods, on the outskirts of Chicago. Mr. Andresen, faithful as ever, was on the job early in the morning to provide tables and benches for the anticipated crowd. At noon the members, their wives, children, and friends began to assemble.

There was the usual softball game, footraces, obstacle races and swimming with nifty prizes for the winners. Refreshments were plentiful. Arrangements were complete down to the last detail.

Much credit is due Mrs. Harry Andresen, for the manner in which she assisted her Chairman husband in planning the picnic and seeing that everything was in order before the members and guests arrived. Mr. Menne of headquarters particularly expressed his gratitude to Mrs. Andresen for her hospitality to all and for per-

mitting him to partake freely of her very tempting lunch basket.

The day was all too short. As the sun set and shades of night began to creep through the trees some of the children, who had been going at top speed all afternoon, began to show signs of weariness. Gradually the jolly crowd broke up but a goodly number stayed to sing songs. This attracted a group of off-duty sailors who were passing by. They were invited to join us and made short work of what remained of the refreshments. It was a fitting way to close a glorious day.



Meetings were resumed in September. If you live in the Chicago area and are not on the Chapter mailing list please get in touch with Chairman Harry Andresen, 3317 No. Albany Ave., Chicago, Phone Juniper 2857.

JOSEPH PAGANO, *Secretary.*

— n r i —

## Earl Merryman To J. E. Smith

Dear J. E. Smith:

"Your letter just received. Sure glad to hear from you. I would like to save the envelope and bring it home to you—it has touched every important war theatre in the South Pacific.

"I sincerely hope that old N.R.I.A.A. will hold my position of Secretary open for me. I would like the thought that I could always hold that position as long as the Alumni Association is still going—just think it has been 14 years since we banded together—time surely flies.

"Well give my regards to all the gang—and I know that they are praying as we are down here that this war will soon end—'73."

Sincerely,

EARL A. MERRYMAN, CRM.  
On overseas duty.

## Baseball At Chicago Chapter Picnic



Harry Andresen and Lou Menne, the captains of the teams, after the softball game. We do not yet know which side won but the score was close—about 39 to 37. It was a great pitchers' duel.

Any fair ball was good for a hit or first base on an error. The first basemen set a world's record. Not a put-out for either. In fact, only about six balls were thrown close enough to the first basemen to catch and they muffed all of them.

The teams were mixed—made up of both men and women. Mixed is right! The only way anyone was put out was to get two or three on the same base at the same time. The traffic was very heavy.

It was quite discouraging to the pitchers, especially Chairman Harry Andresen who held the opposition to 52 hits, some of them only singles. He looked good winding up but lost his stuff in the first inning. They had to leave him in there though because no one else could throw the ball up to the plate.

A highlight of the game was a slide for second base by Clarence Schultz. He took off beautifully in a swan dive but started too soon and came up out of the dust a good six feet short of the base. Was he surprised!

Walter Wilkes had some trouble holding his footing in center field. Several times he slid on the seat of his pants. Walter denies that the cow grazing near him had anything to do with it.

Whenever anyone got hold of the ball there was no telling where he or she might throw it. Your life wasn't worth a nickel. The game was finally called off when Cece Morehead gracefully perched under a fly ball in leftfield only to have it konk him on the head. It was time to quit before someone got killed.

## Men of Science



Michael Faraday, one of the greatest physicists of all time was born in 1791. His discoveries were so far reaching, and so fundamental, that without them our present day radio and electrical development would be unknown.

Unaccustomed to luxury in early life, for his father was a blacksmith and earned only a modest income, Faraday had little opportunity for formal education and labored during his youth as an apprentice to a bookbinder, gaining much of his knowledge by reading. He worked as a journeyman bookbinder until twenty-two years of age and then began a series of experiments at home which attracted the attention of Sir Humphrey Davy, through whose influence he obtained an appointment as an assistant in the laboratory of the Royal Institution of Great Britain. He made excellent use of his opportunity and in 1825 was made Director of the Laboratory. In 1833, he received for life an appointment as Fullerian Professor of Chemistry.

The farad, unit of capacity, is named after Faraday. Because the farad is too large for practical purposes, its millionth part, a microfarad, is used in radio.

It was in 1831 that Faraday obtained the first evidence electricity in one circuit can be induced in another, but his experiments in electromagnetic induction continued for ten years until, in a now famous paper which he read to the Royal Society, on November 24, 1841, he definitely established the principle of induction. This fundamental principle is put to work in every electric motor, transformer and radio coil. It revolutionized electrical science and made possible the later development of radio and all the other branches of electricity.

In 1867, at the age of 76, Michael Faraday died. But his achievements lived on, and he will ever be an inspiration to those who follow the road of experimental research.

Page Thirty-two

# NATIONAL RADIO NEWS

FROM N. R. I. TRAINING HEADQUARTERS

Vol. 10

No. 11

October-November, 1943

Published every other month in the interest of the students and Alumni Association of the

NATIONAL RADIO INSTITUTE  
Washington, D. C.

The Official Organ of the N. R. I. Alumni Association  
Editorial and Business Office, 16th & You Sts., N. W.,  
Washington, D. C.

L. L. MENNE, EDITOR

J. B. STRAUGHN, TECHNICAL EDITOR

NATIONAL RADIO NEWS accepts no paid advertising. Articles referring to products of manufacturers, wholesalers, etc., are included for readers' information only, and we assume no responsibility for these companies or their products.

## Index

Article	Page
Editorial .....	2
Hints for Wartime Servicing Problems .....	3
Sample Questions and Answers for Radio	
Operator License Examinations .....	10
Novel Radio Items .....	14
Postal Delivery Zone Numbers .....	15
Ohmmeters and How to Use Them .....	16
Alumni Nominations .....	25
Alumni Chapter News .....	27
Here and There Among Alumni Members .....	28
Alumni Nomination Ballot .....	30
Men of Science .....	32